



EXPERT WP 6000



TECHNICAL CATALOGUE

Contents

6-Chamber System	1-10
Assemblies	11-23
Drainage diagram	24
Milling	25
Scheme	26-28
Reinforced profiles	29-30
Calculation of the moment of inertia	31
Formulas	32-33
Profile with polish cover	34

TECHNICAL CATALOGUE PVC SYSTEM EXPERT WP 6000

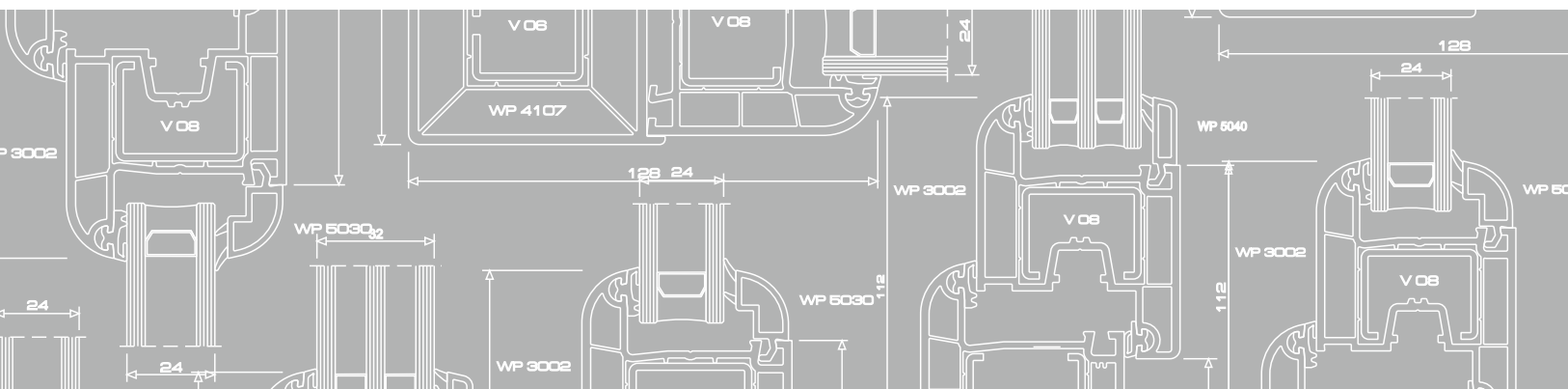

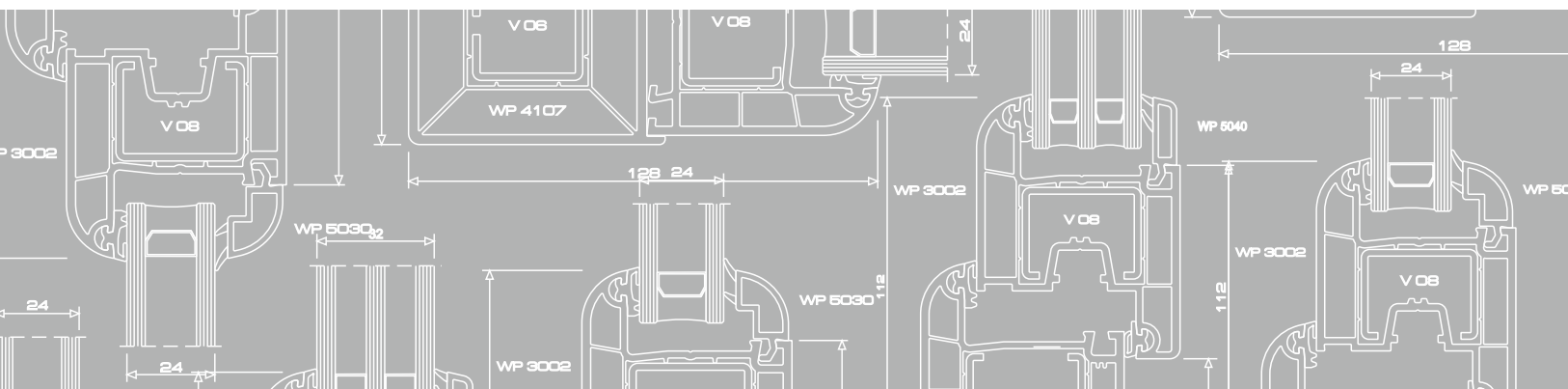

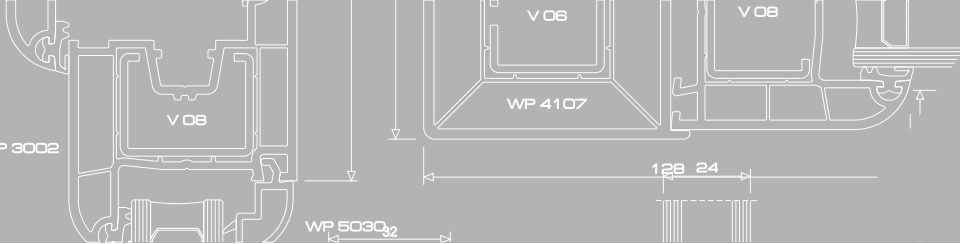

EXPERT WP 6000

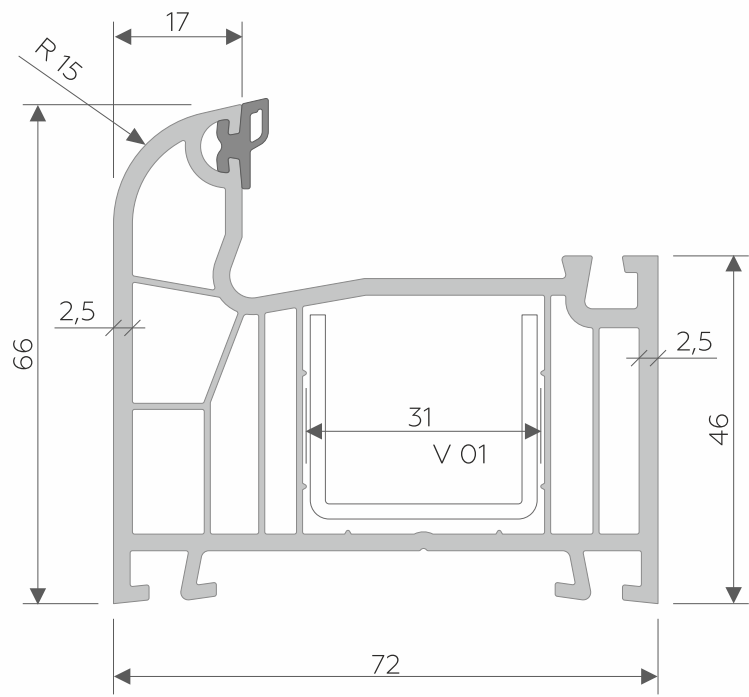

Frame profile
WP 6001
EXPERT

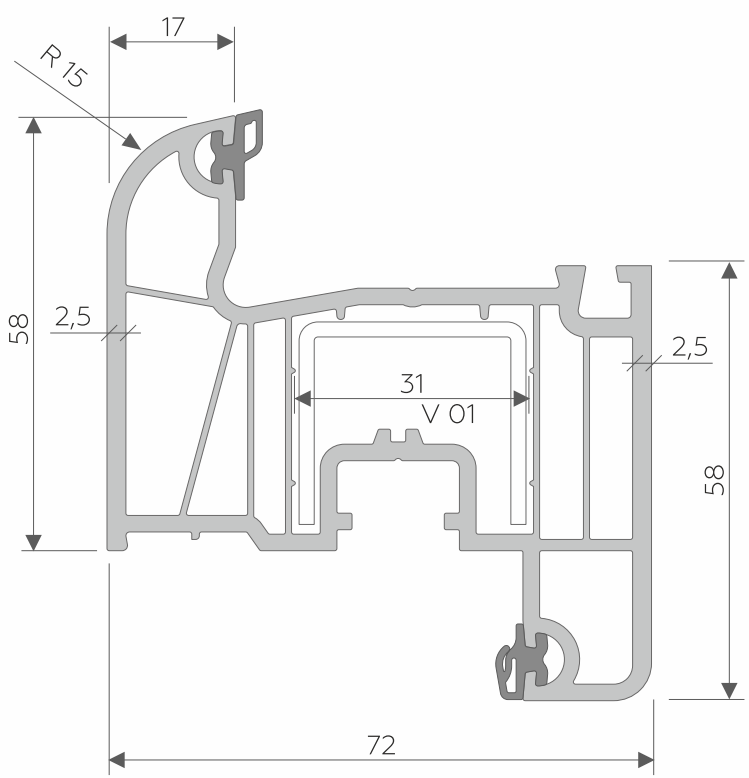

Sash profile
WP 6002
EXPERT

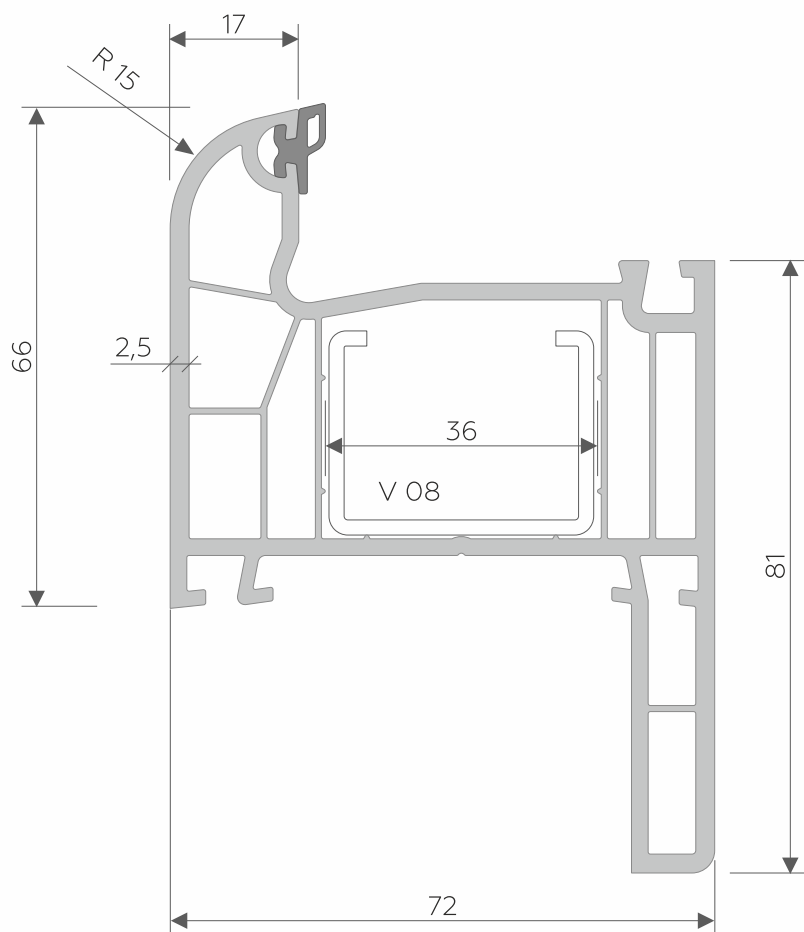
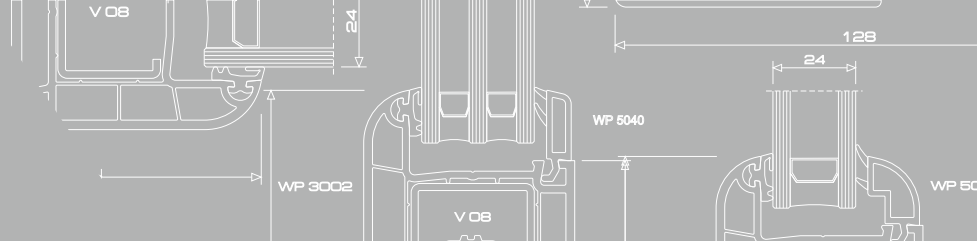

Frame profile

WP 5035
ENERGY

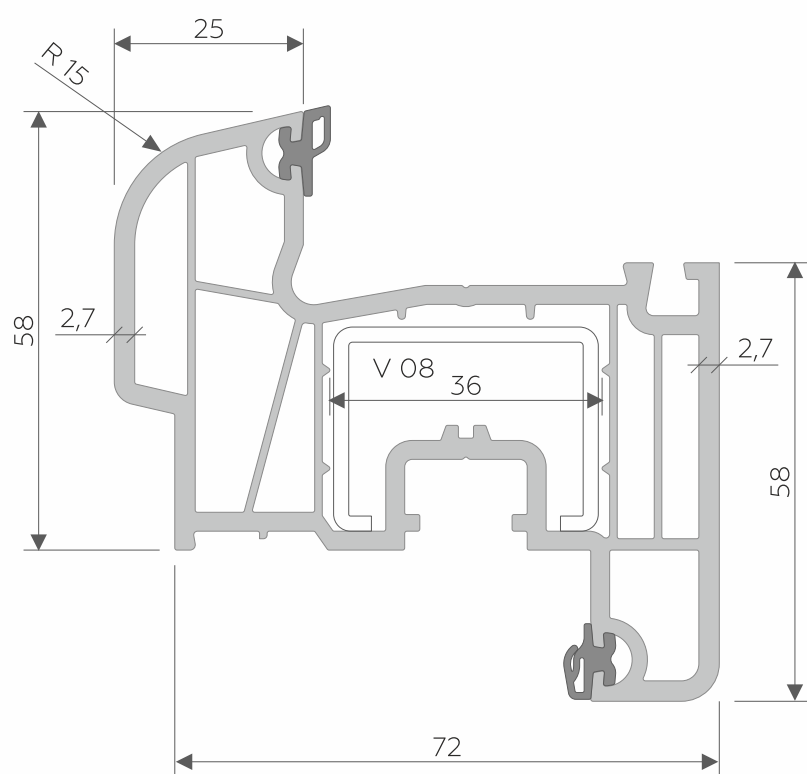

Sash profile

WP 5010
ENERGY

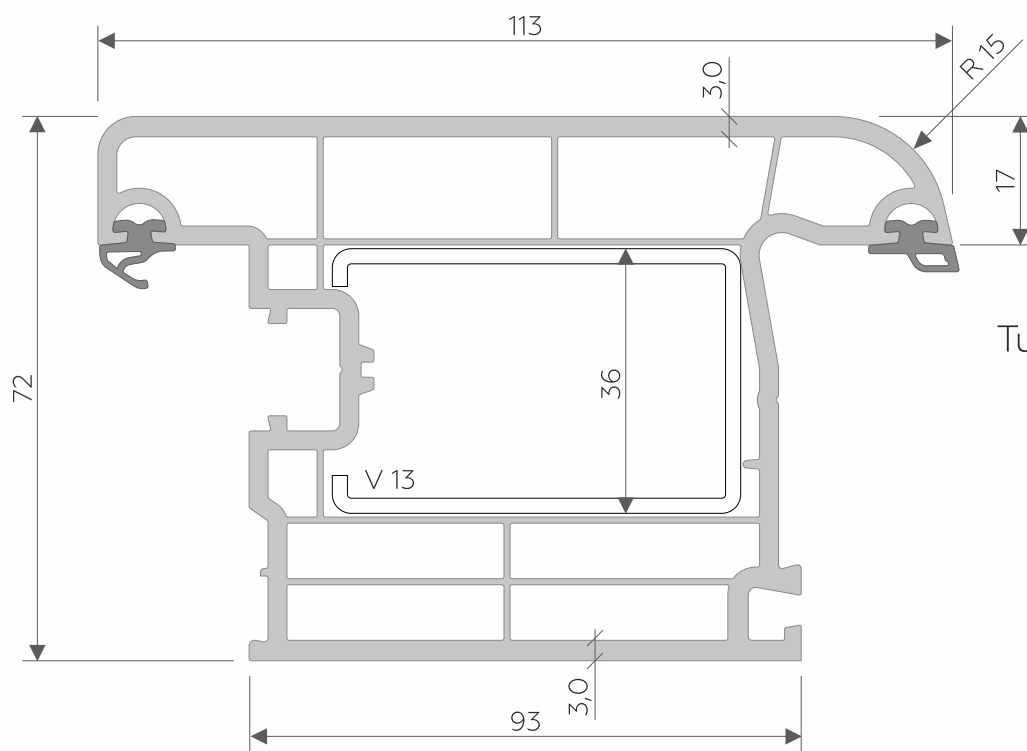

Turned over door
sash profile

WP 5005
ENERGY

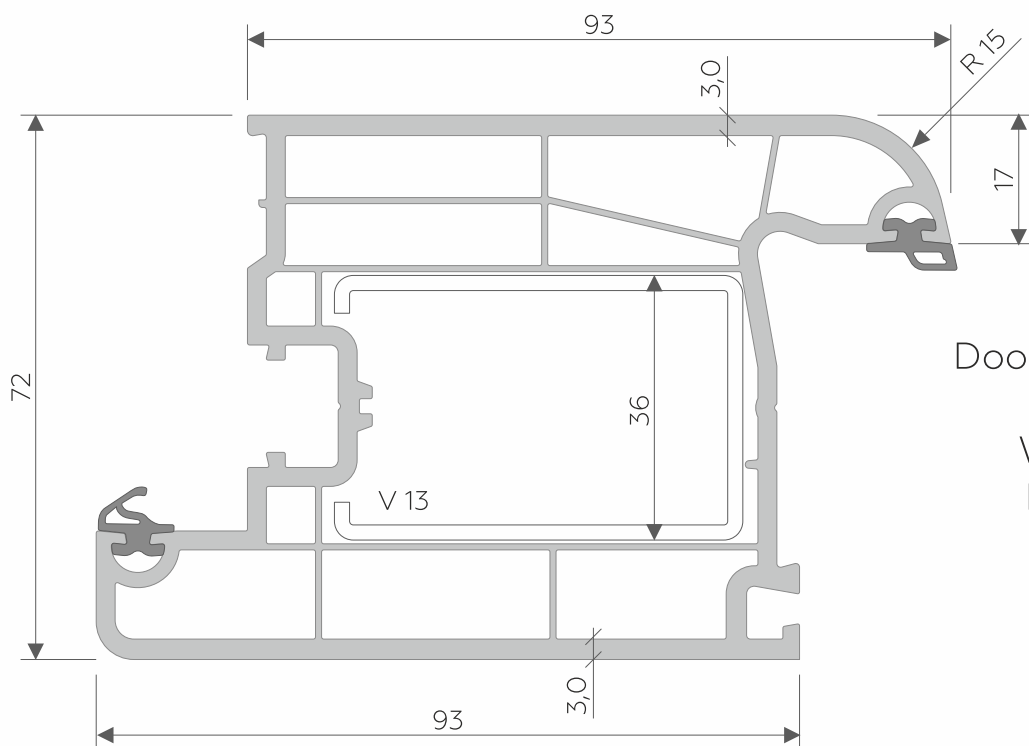

Door sash profile

WP 5004
ENERGY

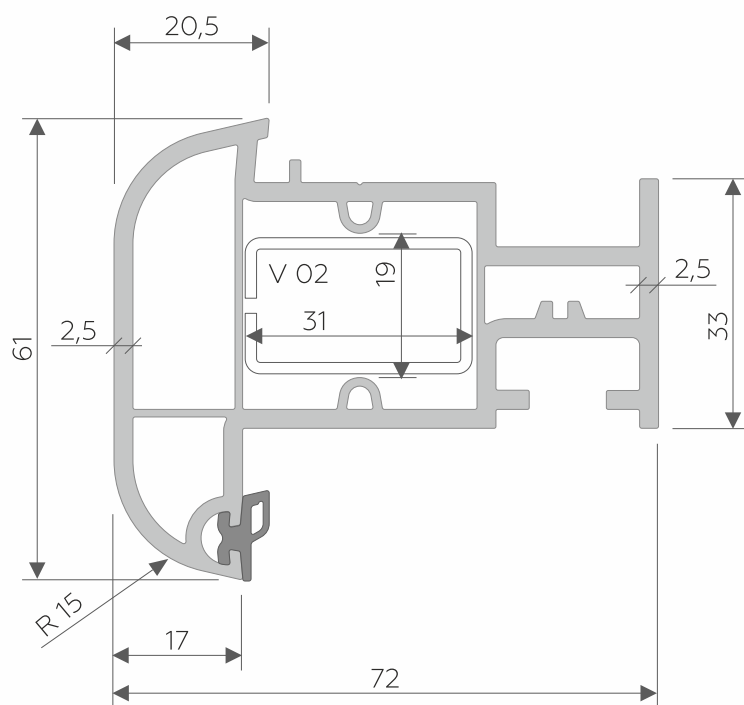
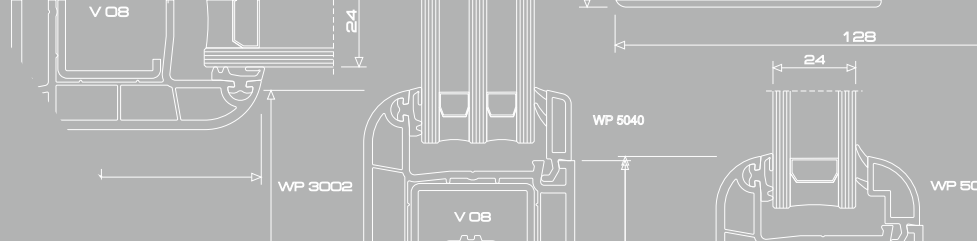

Lap joint profile

WP 5006
ENERGY

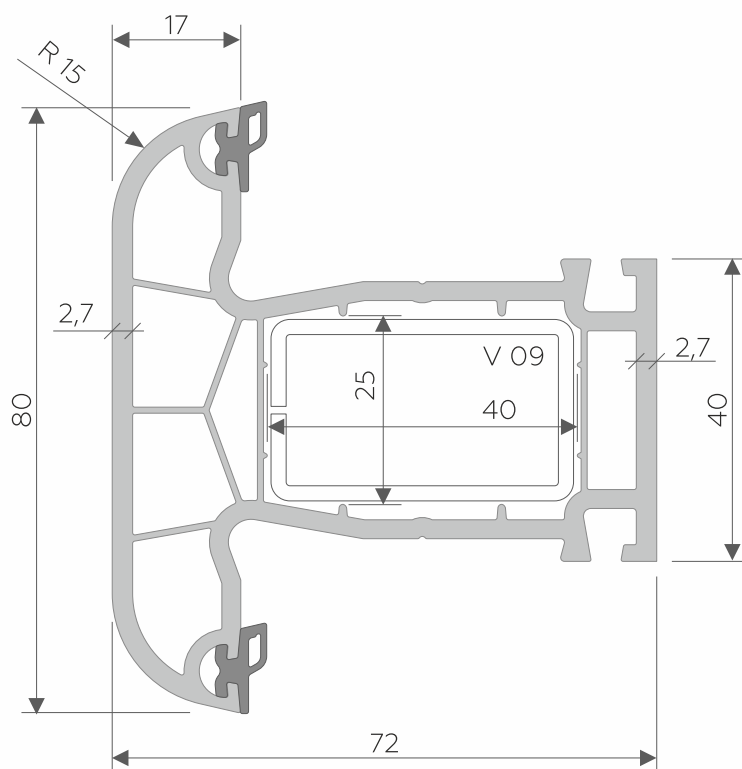

Mullion profile

WP 5003
ENERGY

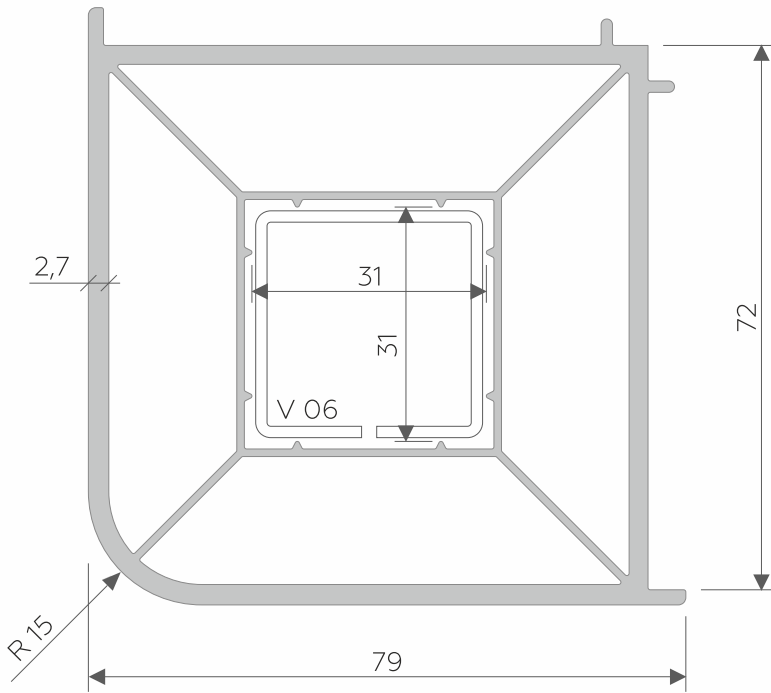
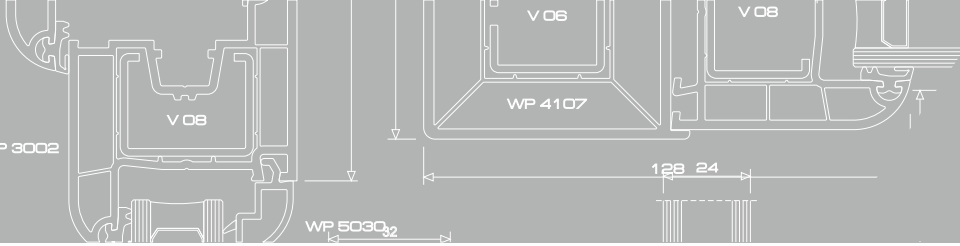

Corner profile 90°

WP 5007
ENERGY

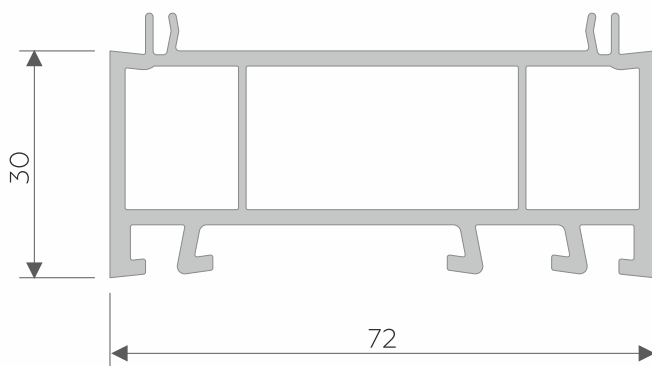

Frame extension

WP 5008
ENERGY

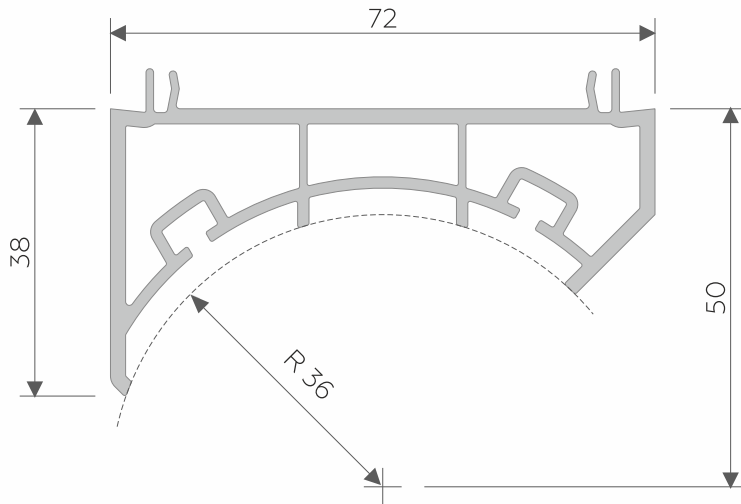
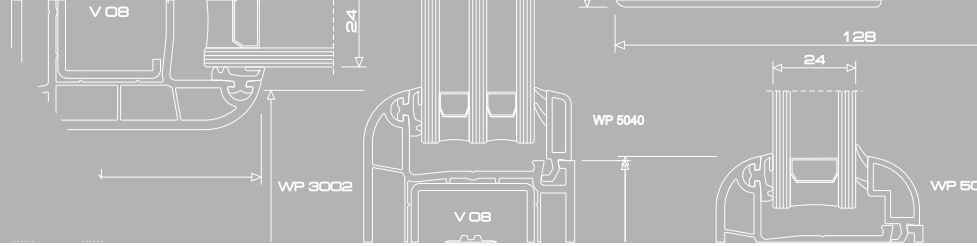

Corner lag profile

WP 5009
ENERGY

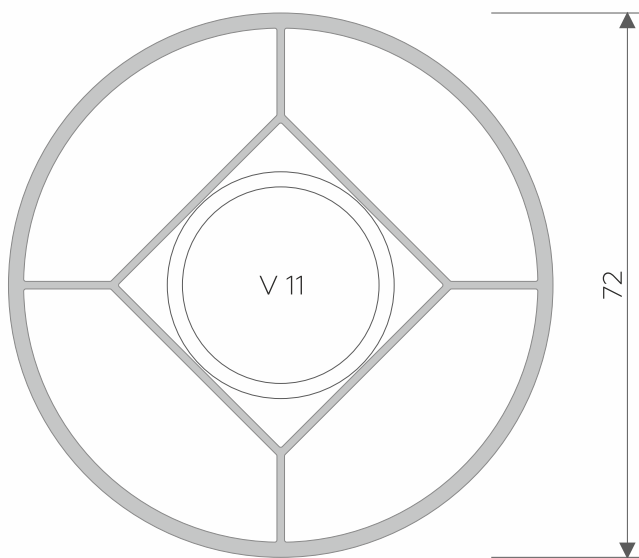

Pipe profile

WP 5011
ENERGY

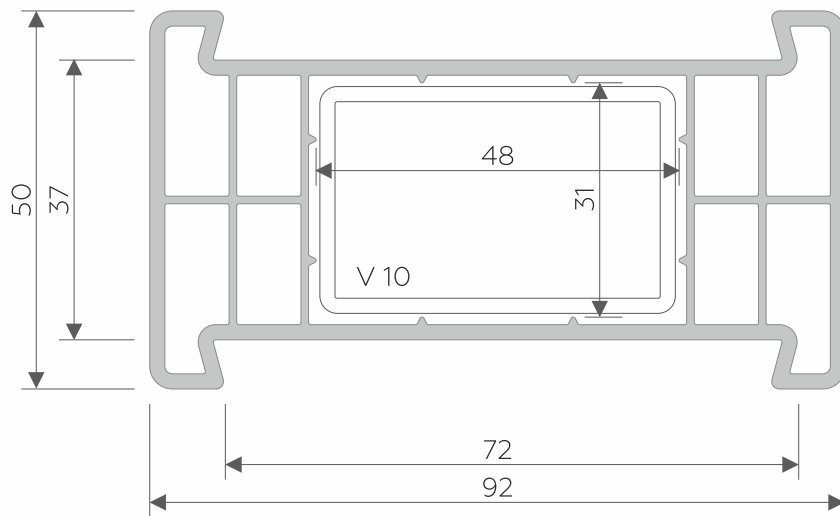

Coupling profile

WP 5013

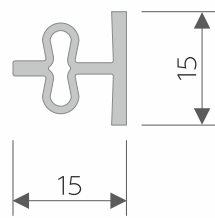

Coupling profile

WP 5012

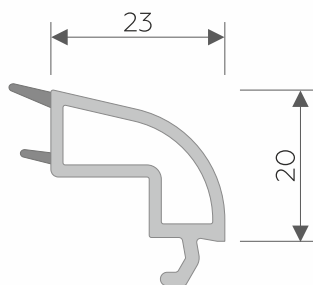

Glass bead 24 mm

WP 5020

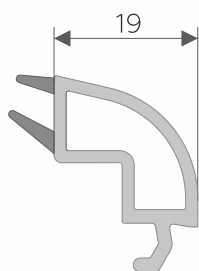
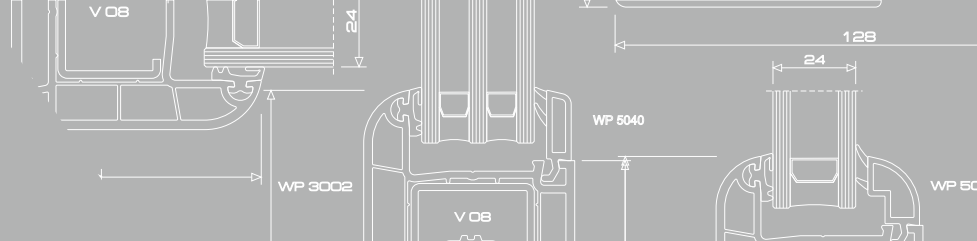

Glass bead 28 mm

WP 5028

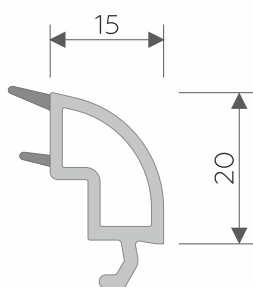

Glass bead 32 mm

WP 5030

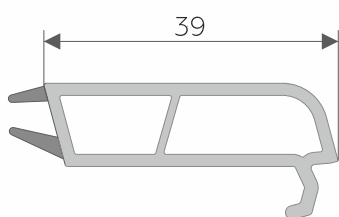

Glass bead 12 mm

WP 5034

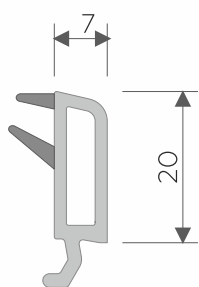

Glass bead 40 mm

WP 5040

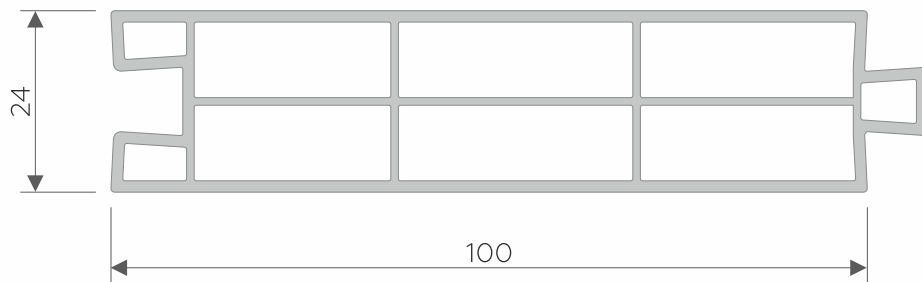
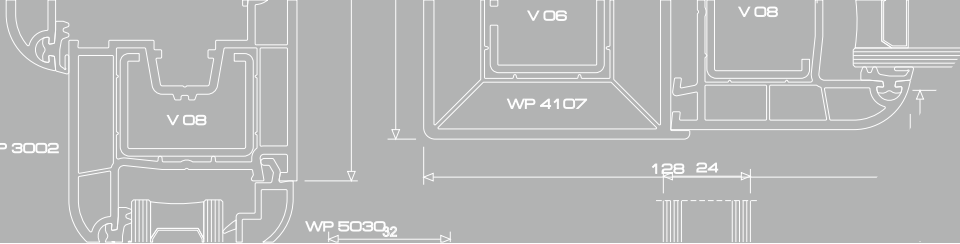

PVC panel 24 mm

WP 4119

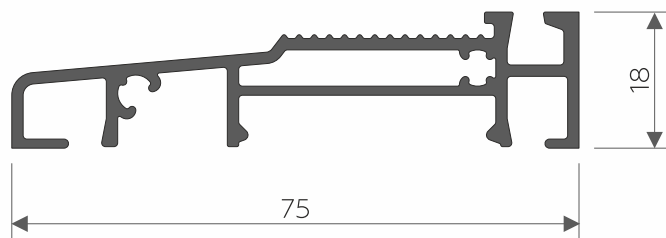

Aluminum door - sill

WP 5065

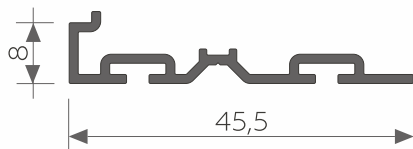

Additional profile for door

WP 4066

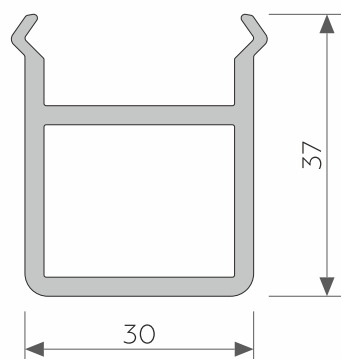

Lifting profile

WP 4123

EXPERT WP 6000

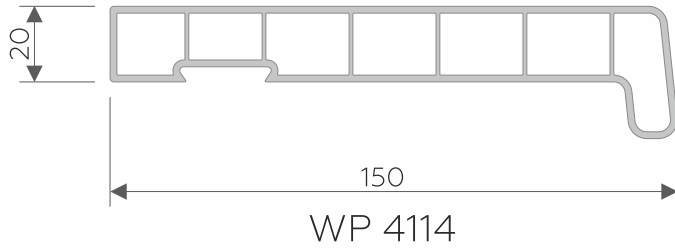
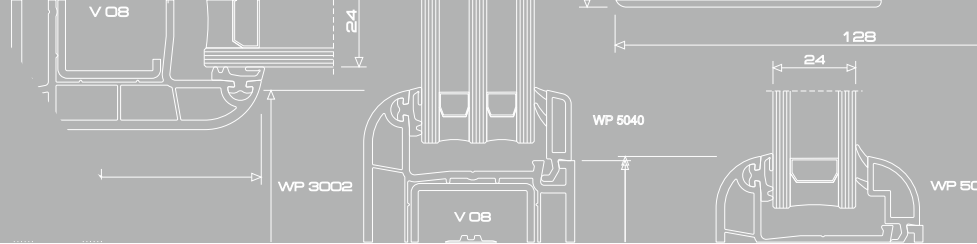

Under window profile internal

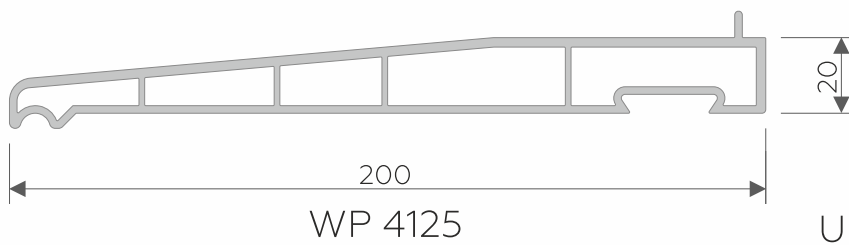
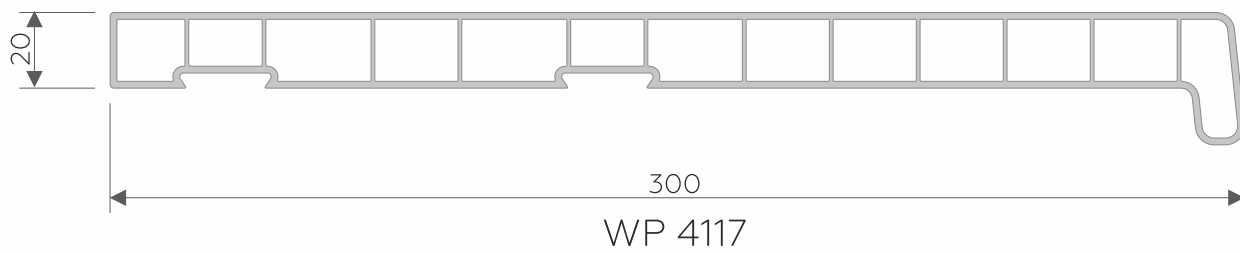
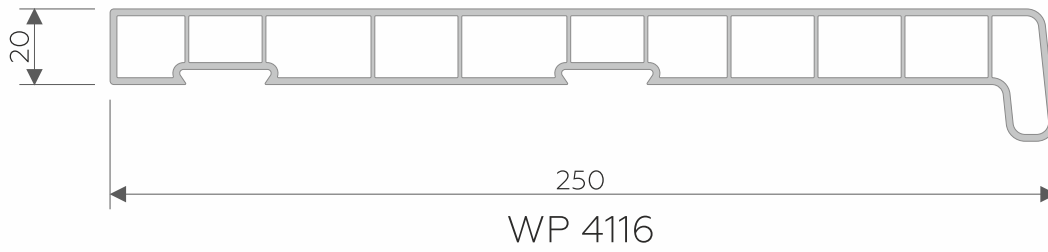
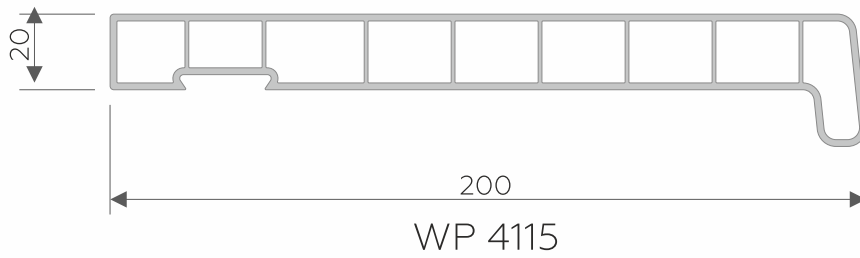

Under window profile internal

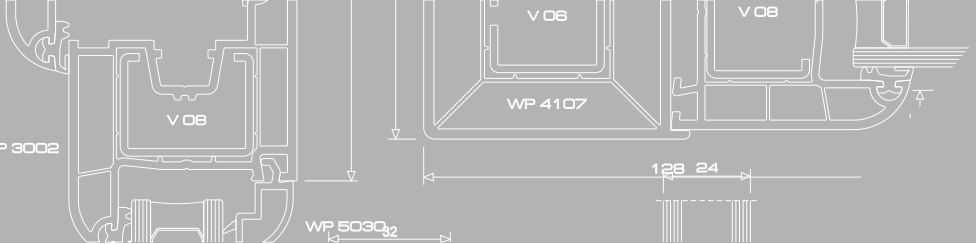

EXPERT WP 6000

Assemblies

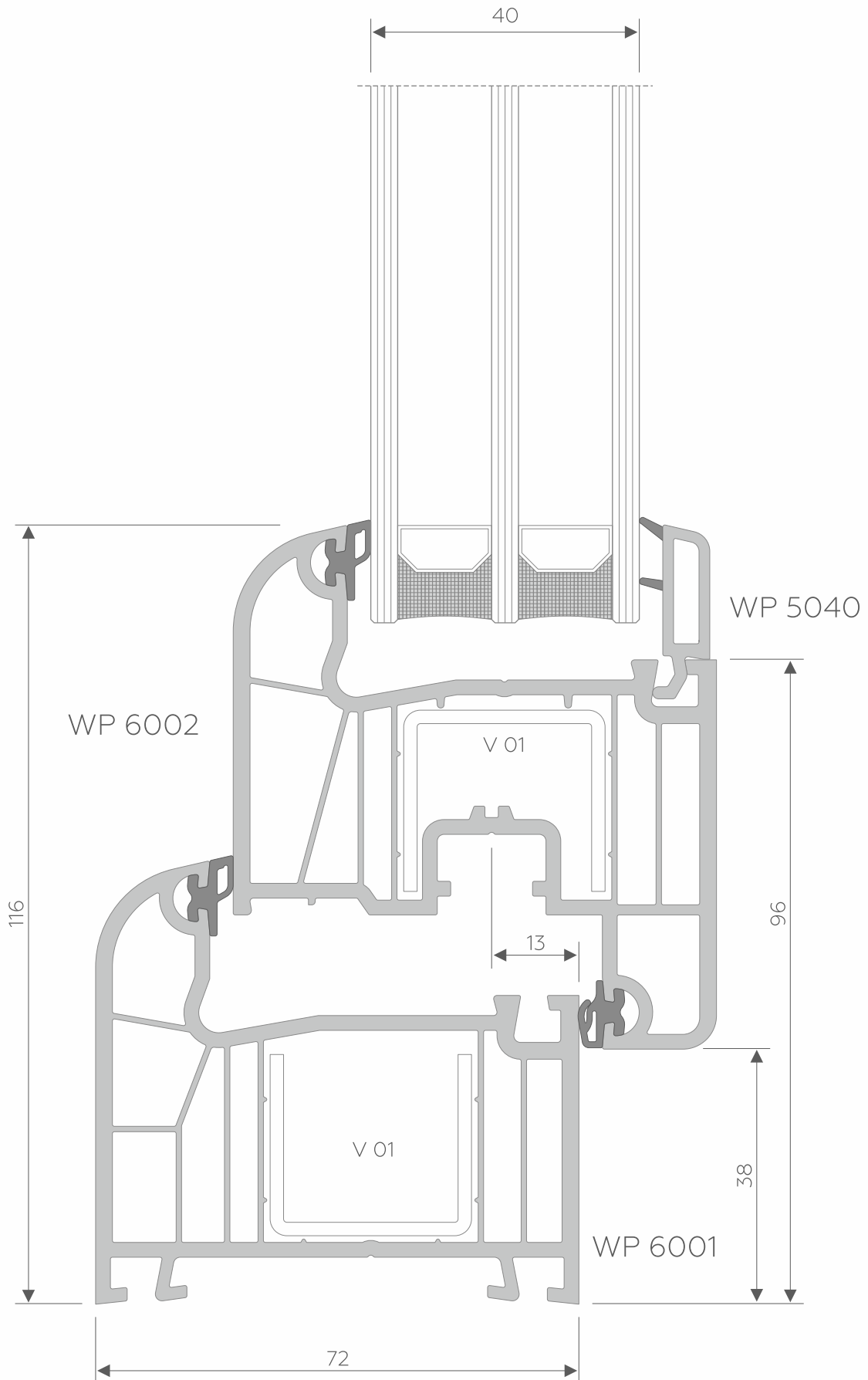

EXPERT WP 6000

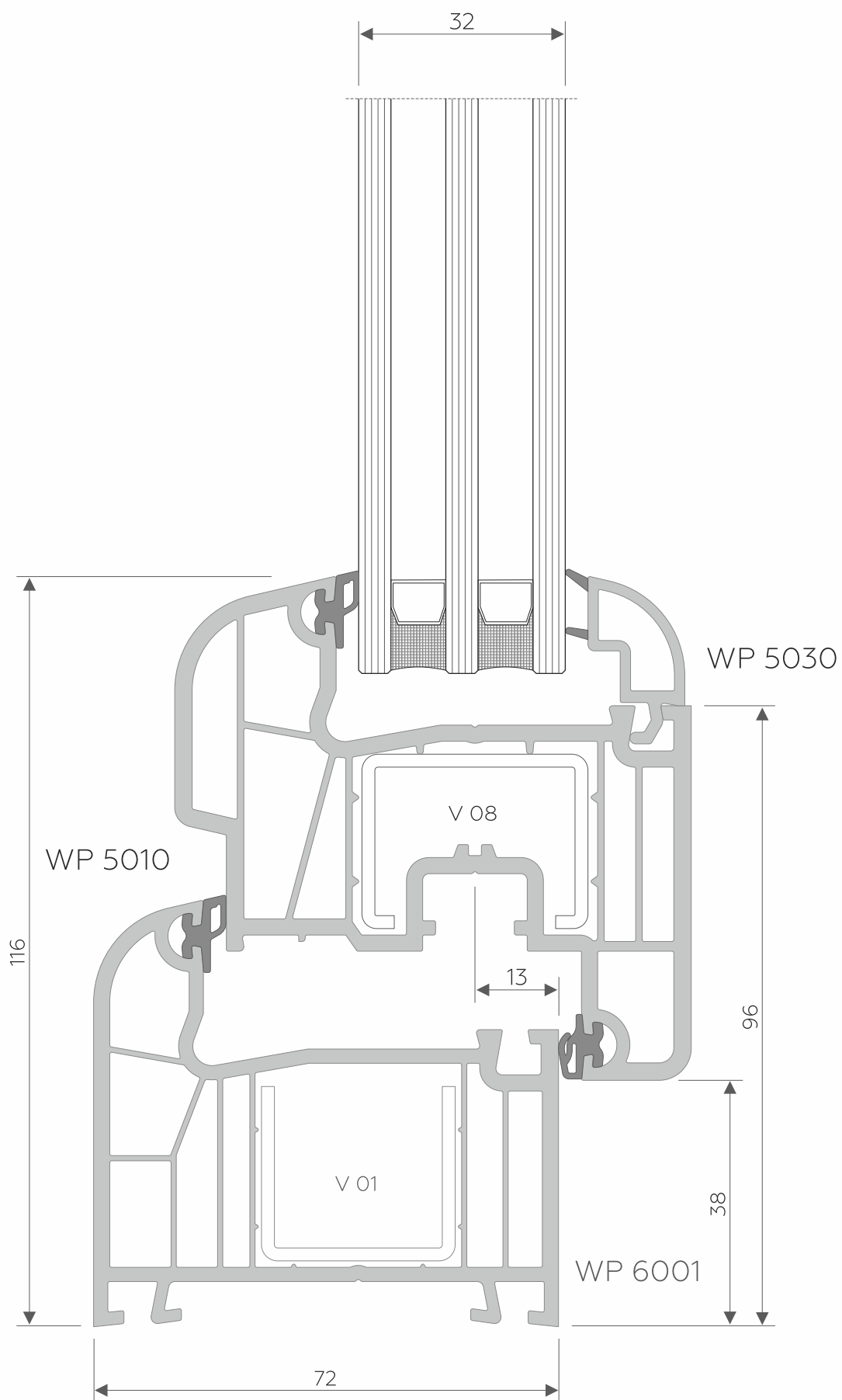

EXPERT WP 6000

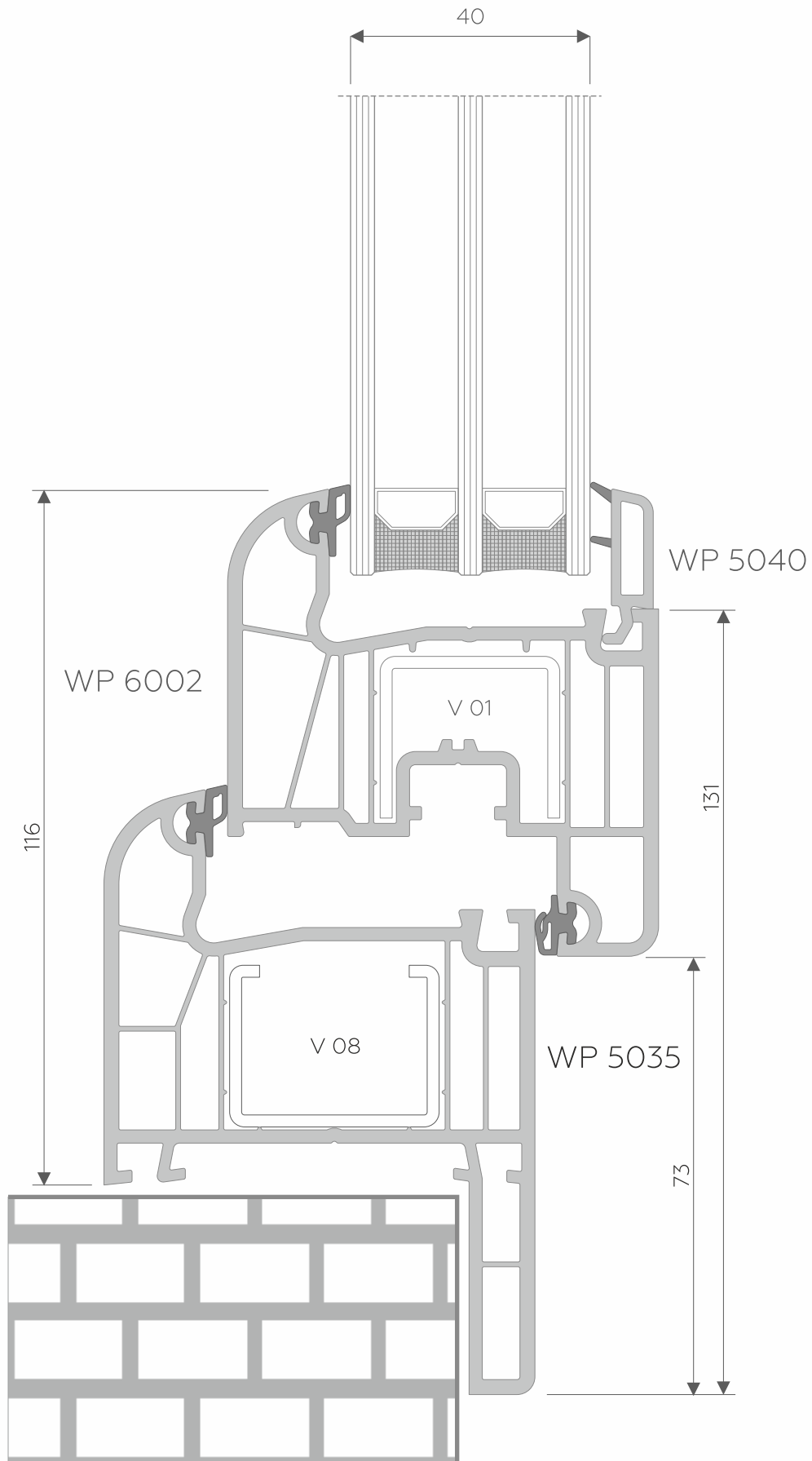

EXPERT WP 6000

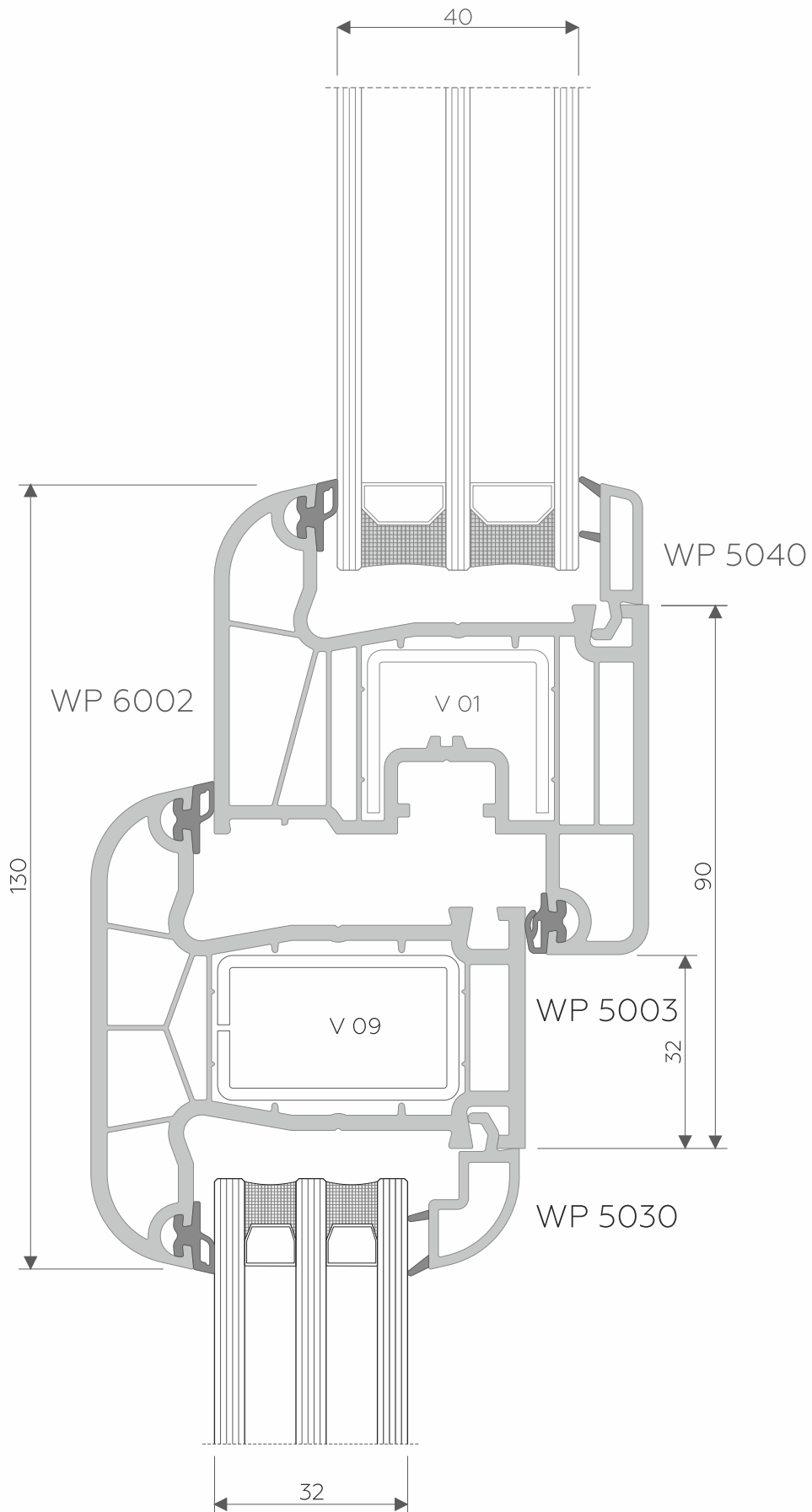

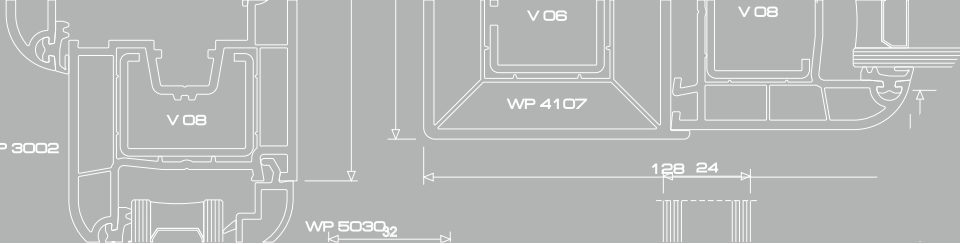

EXPERT WP 6000

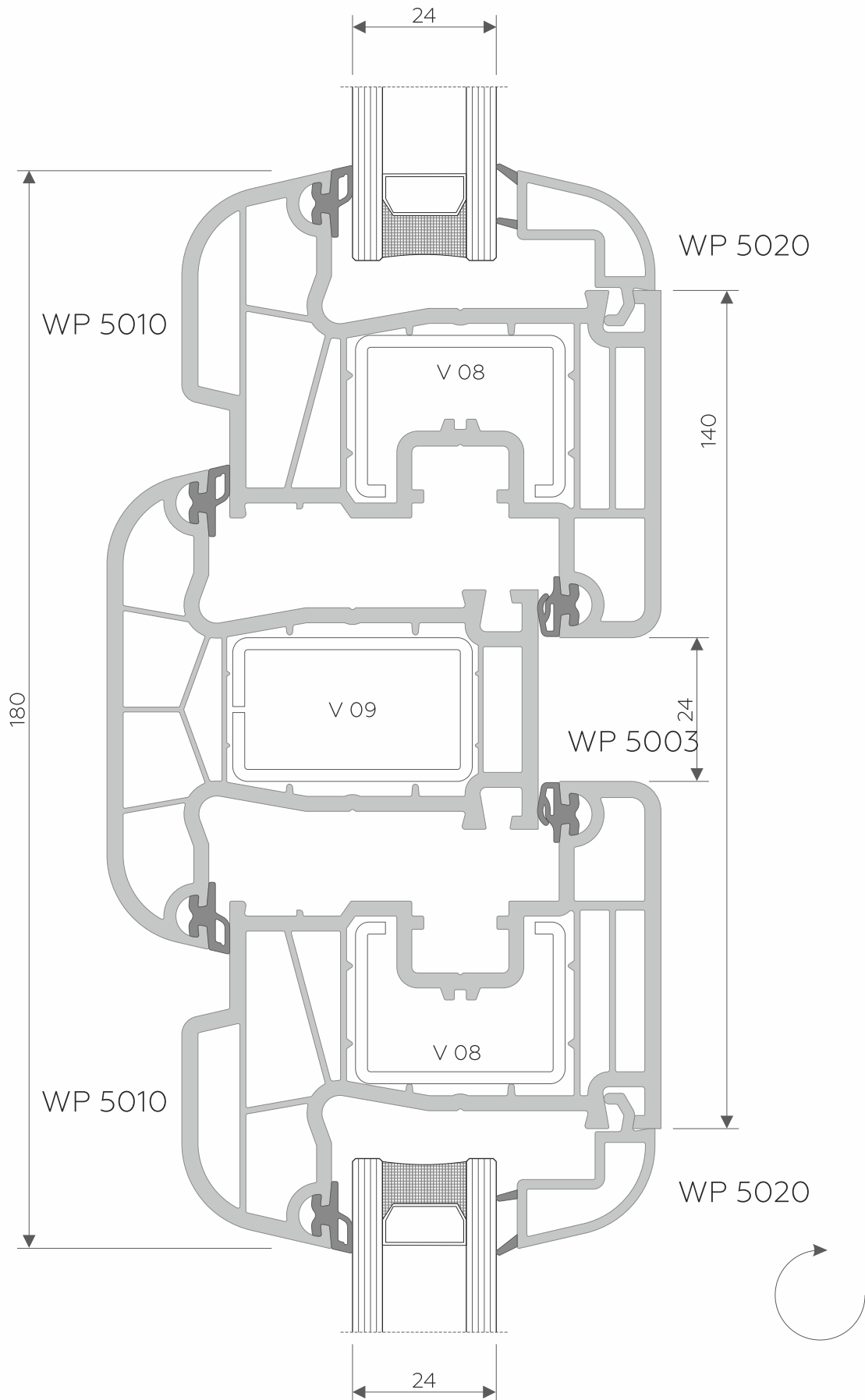

EXPERT WP 6000

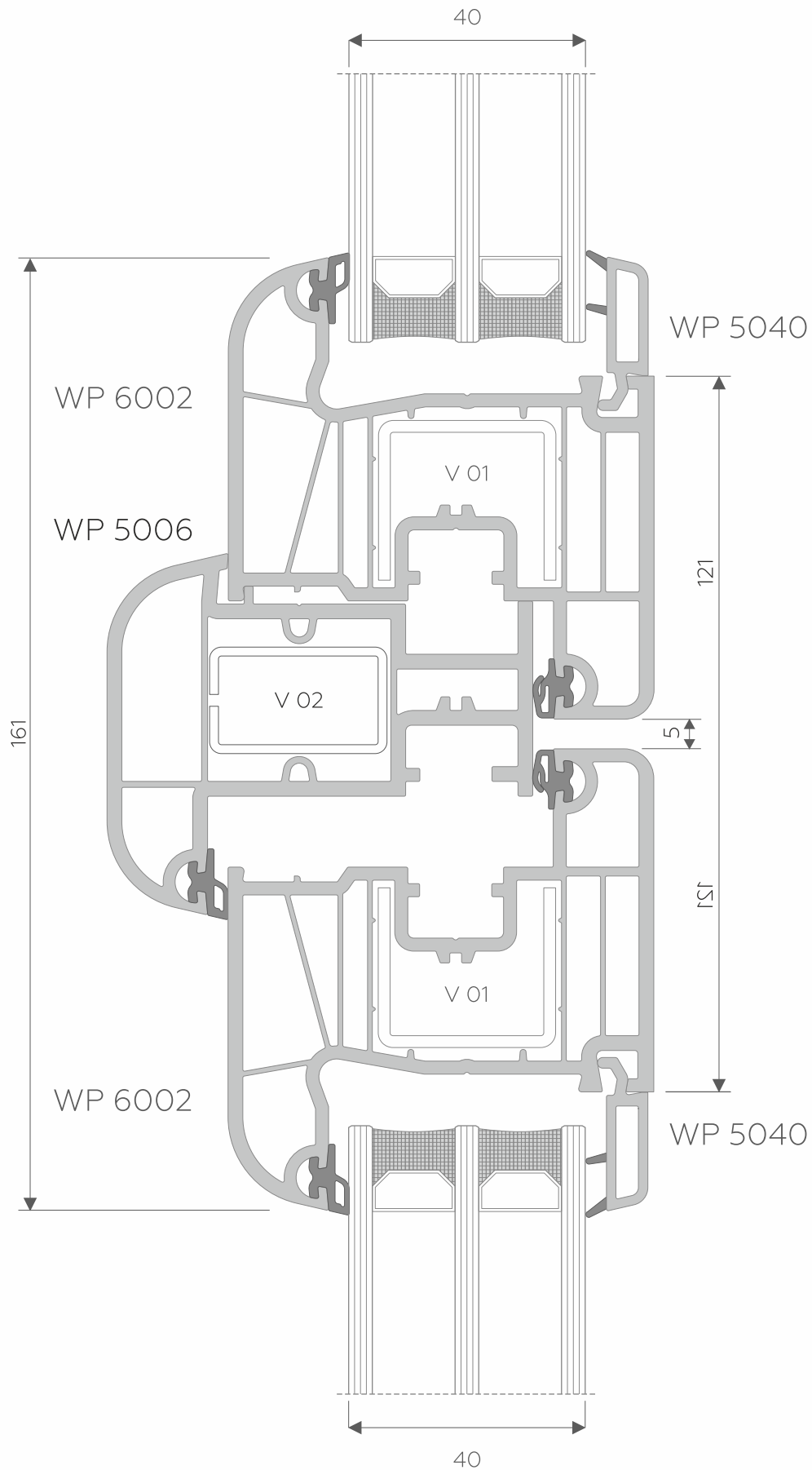

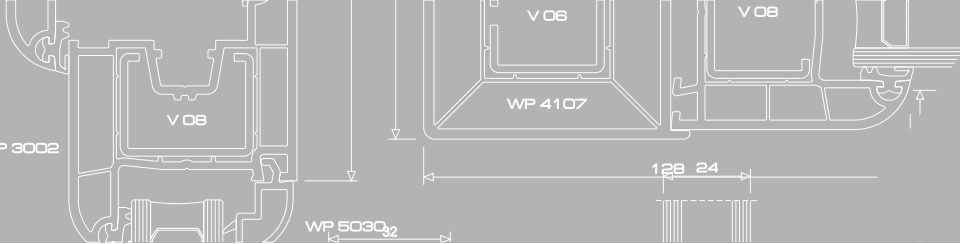

EXPERT WP 6000

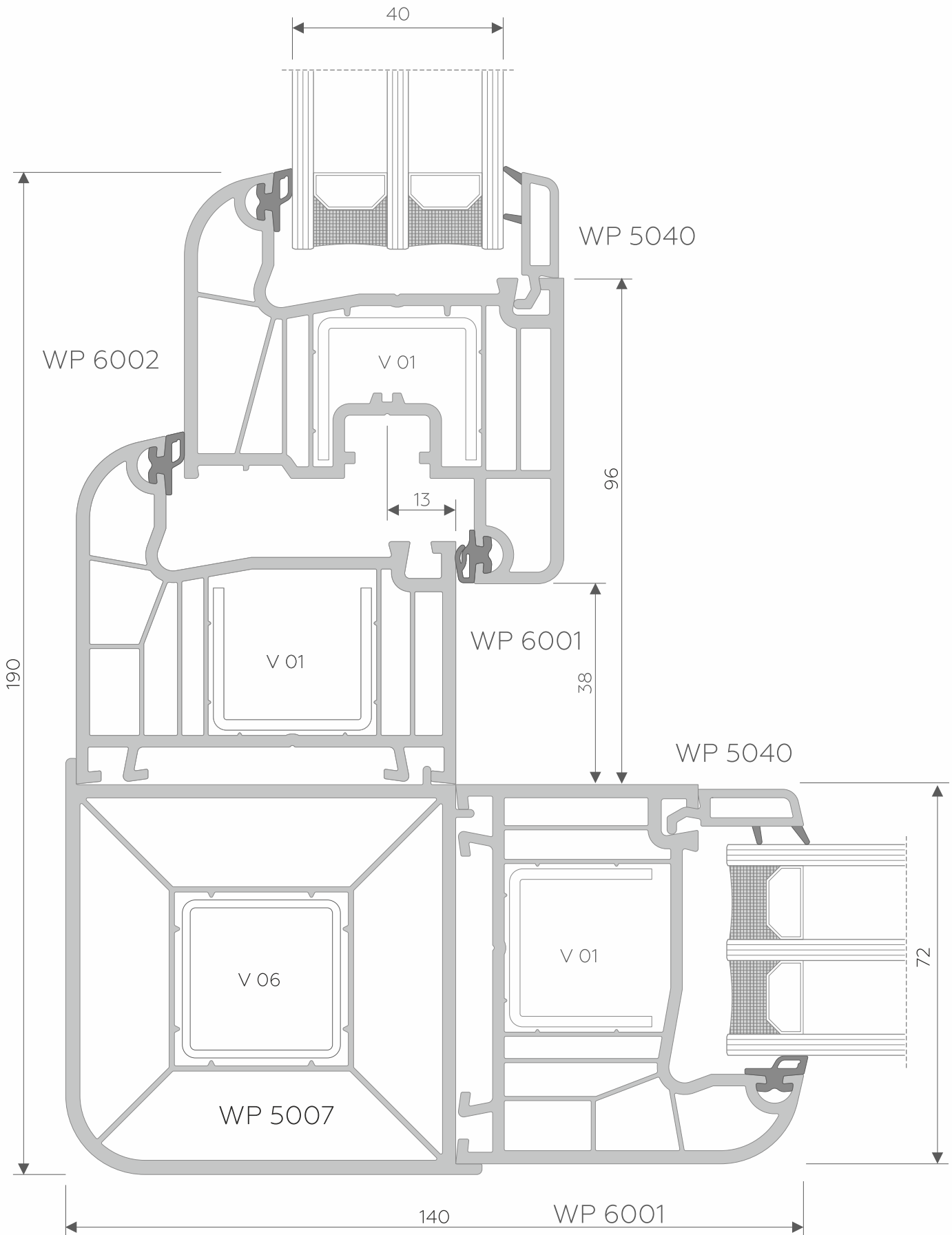

EXPERT WP 6000

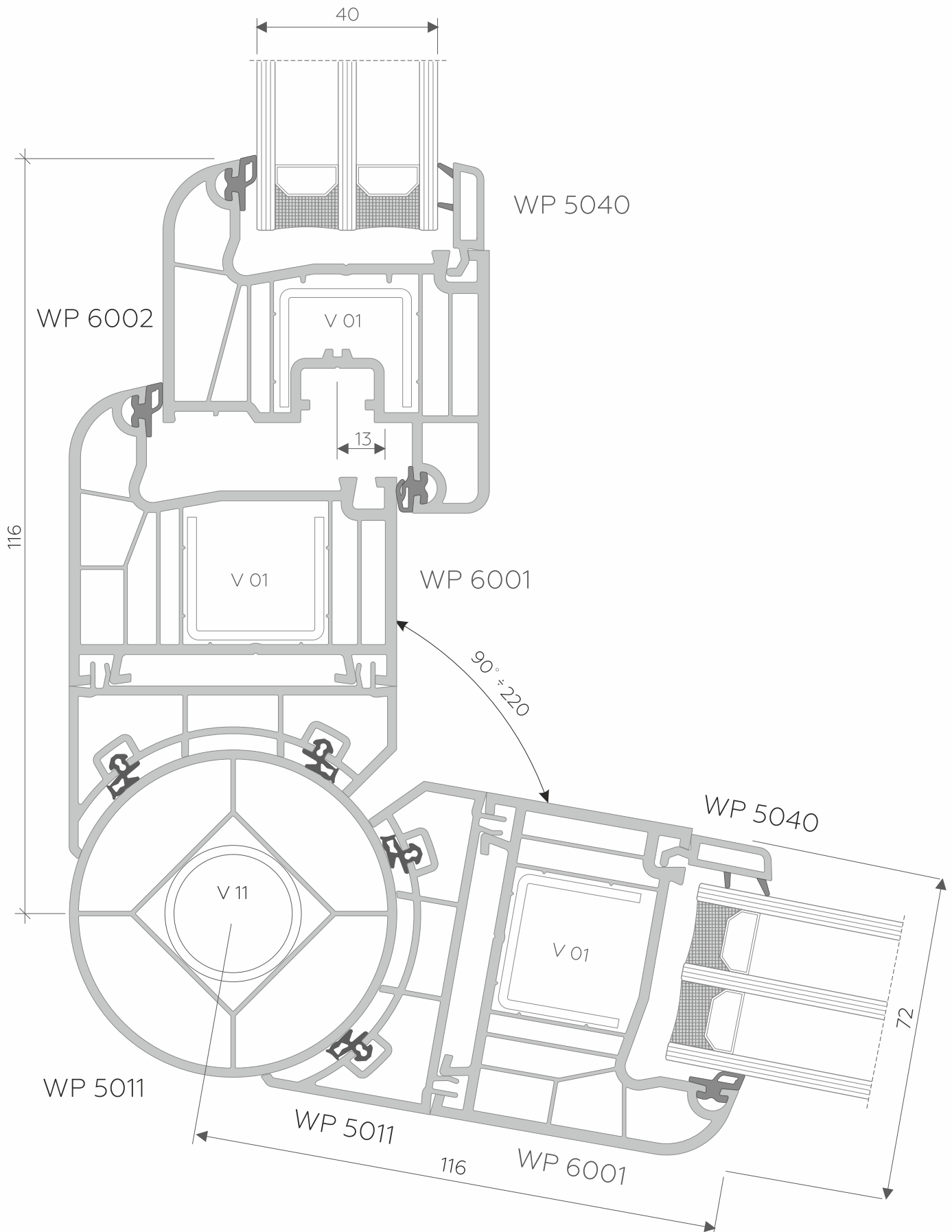

EXPERT WP 6000

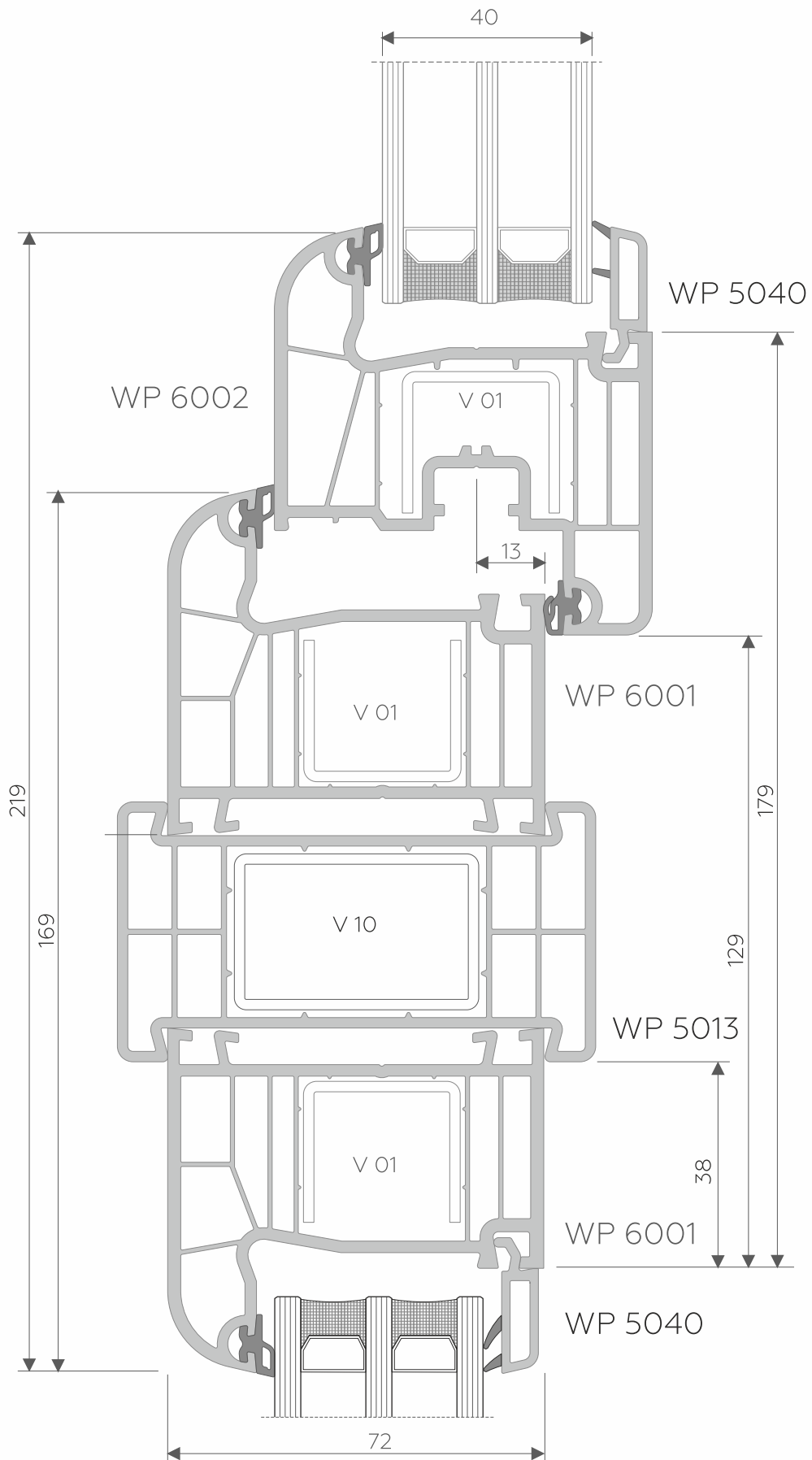

EXPERT WP 6000

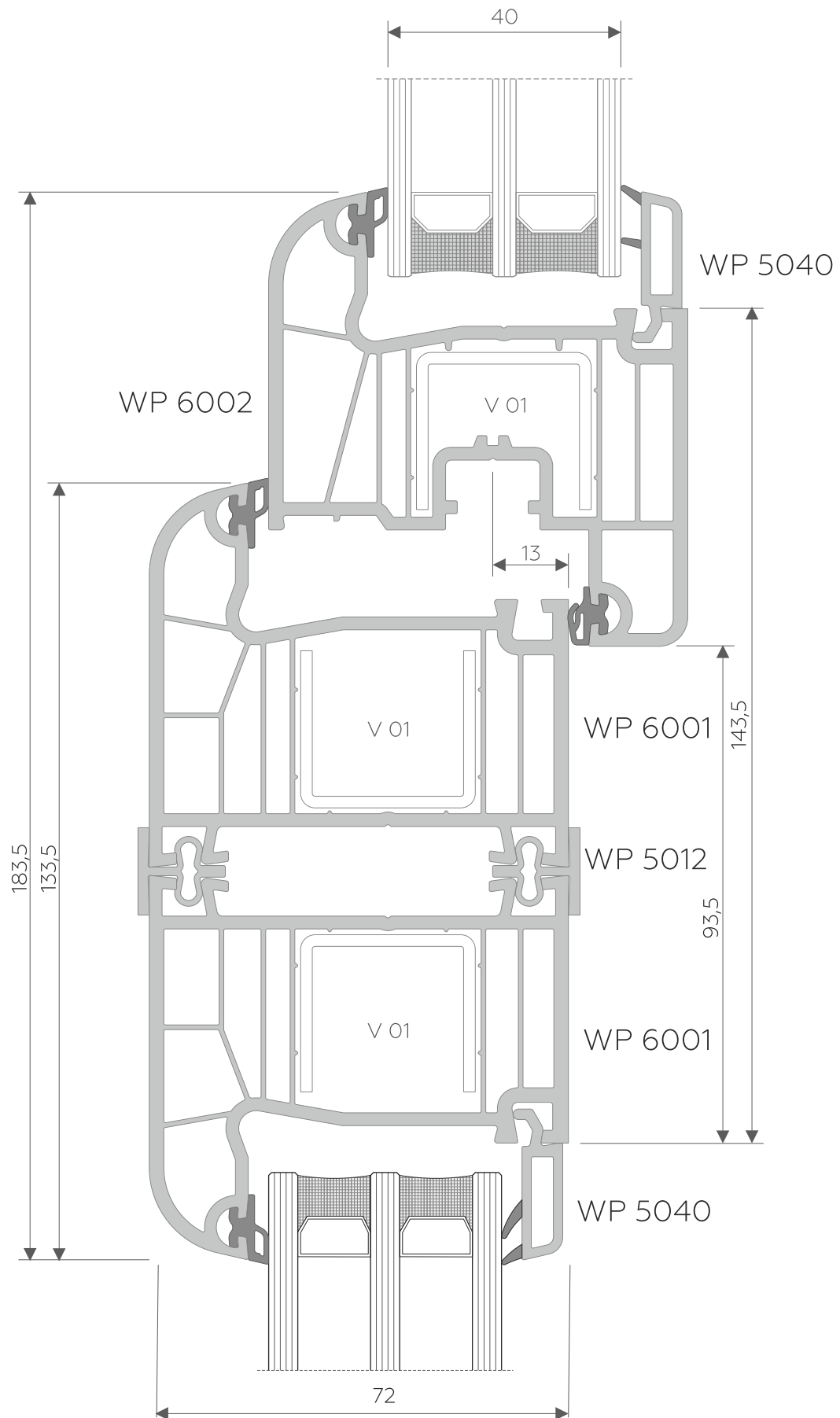

EXPERT WP 6000

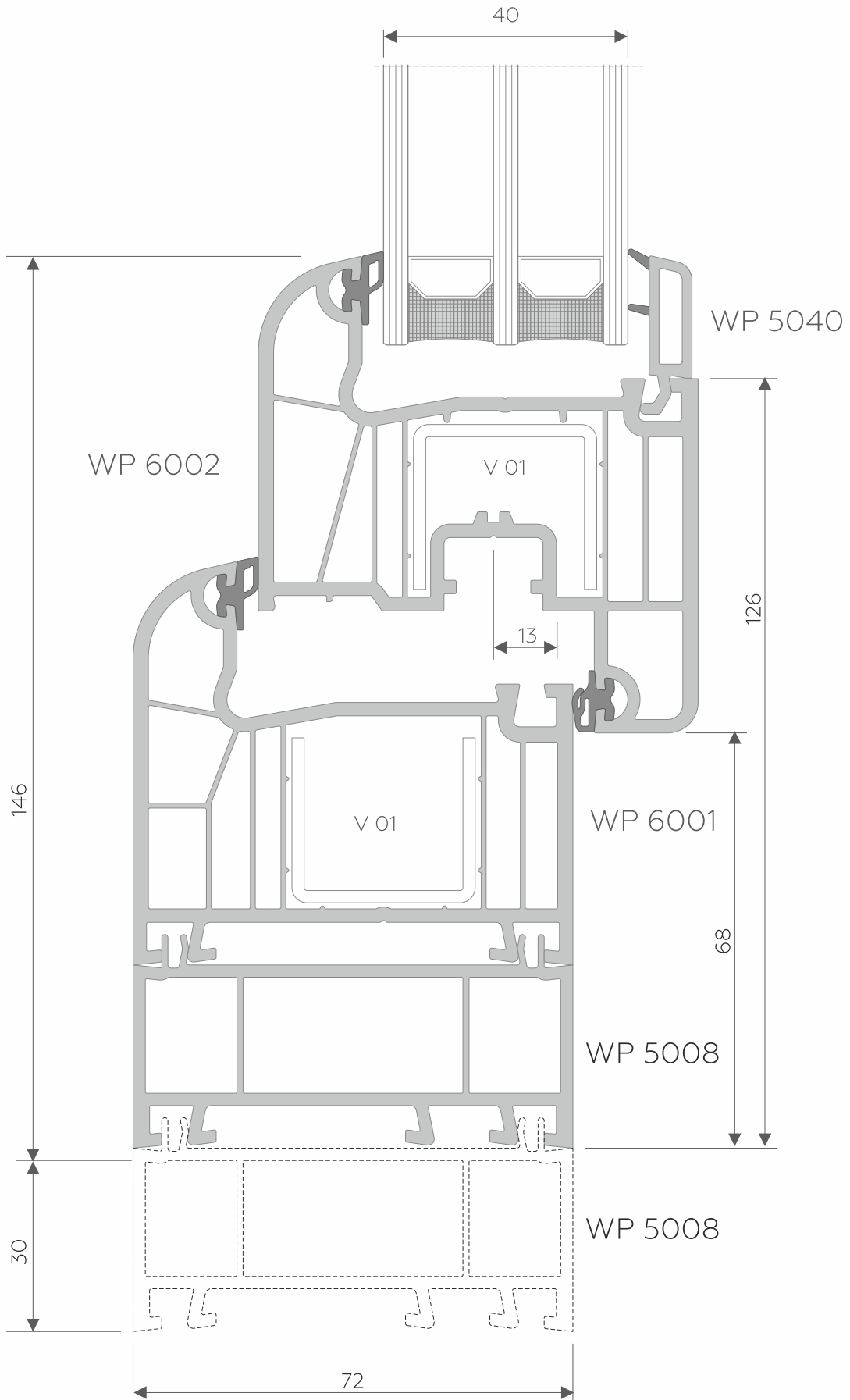

EXPERT WP 6000

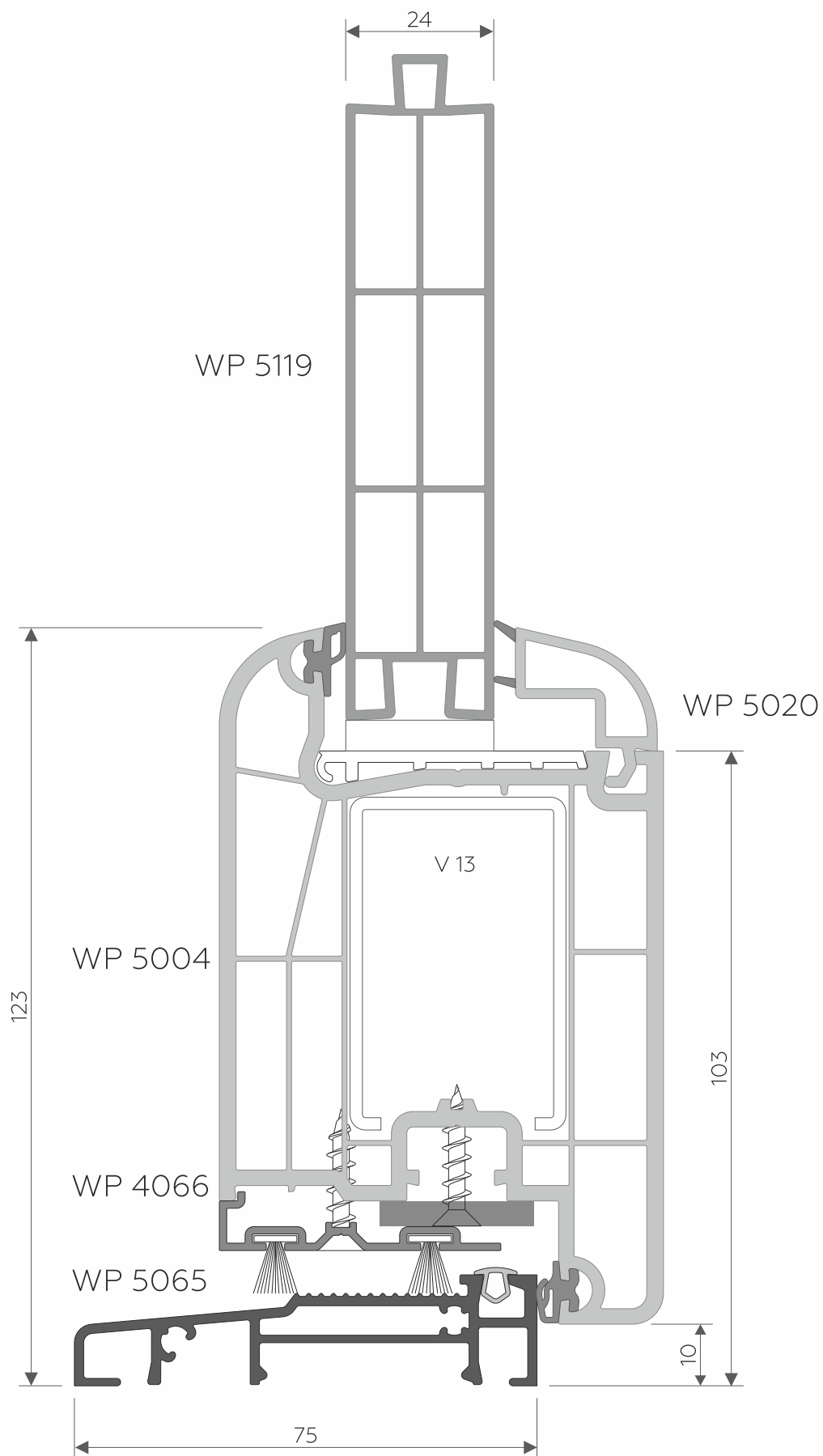

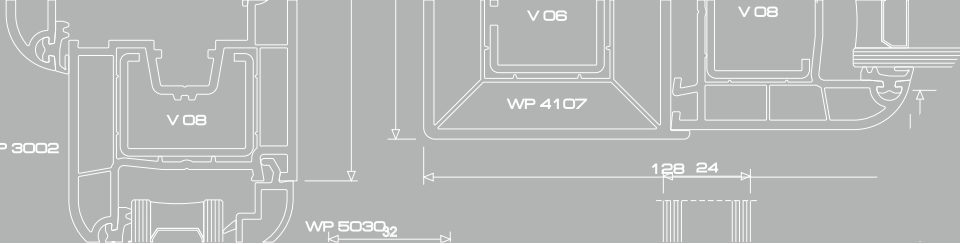

EXPERT WP 6000

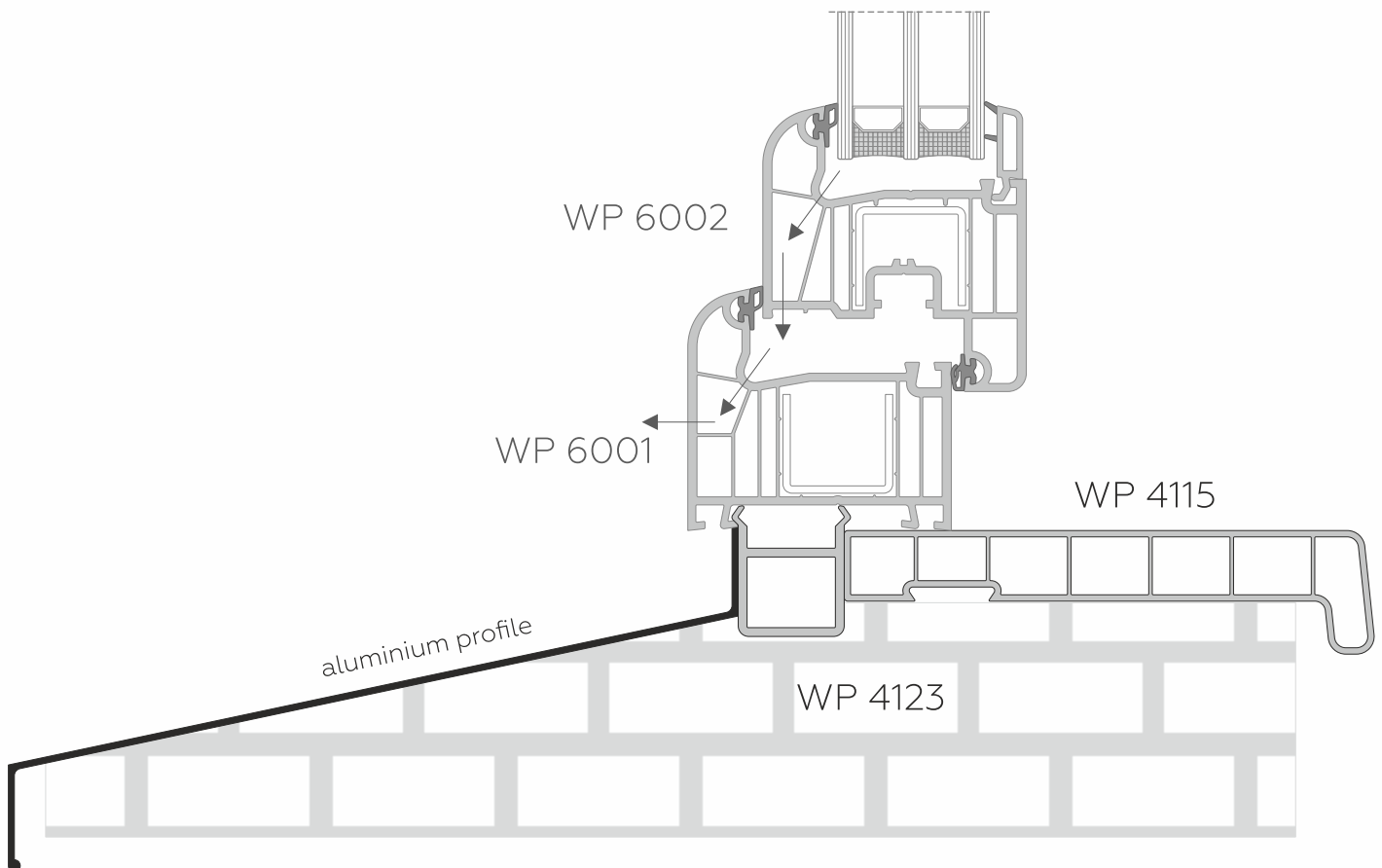
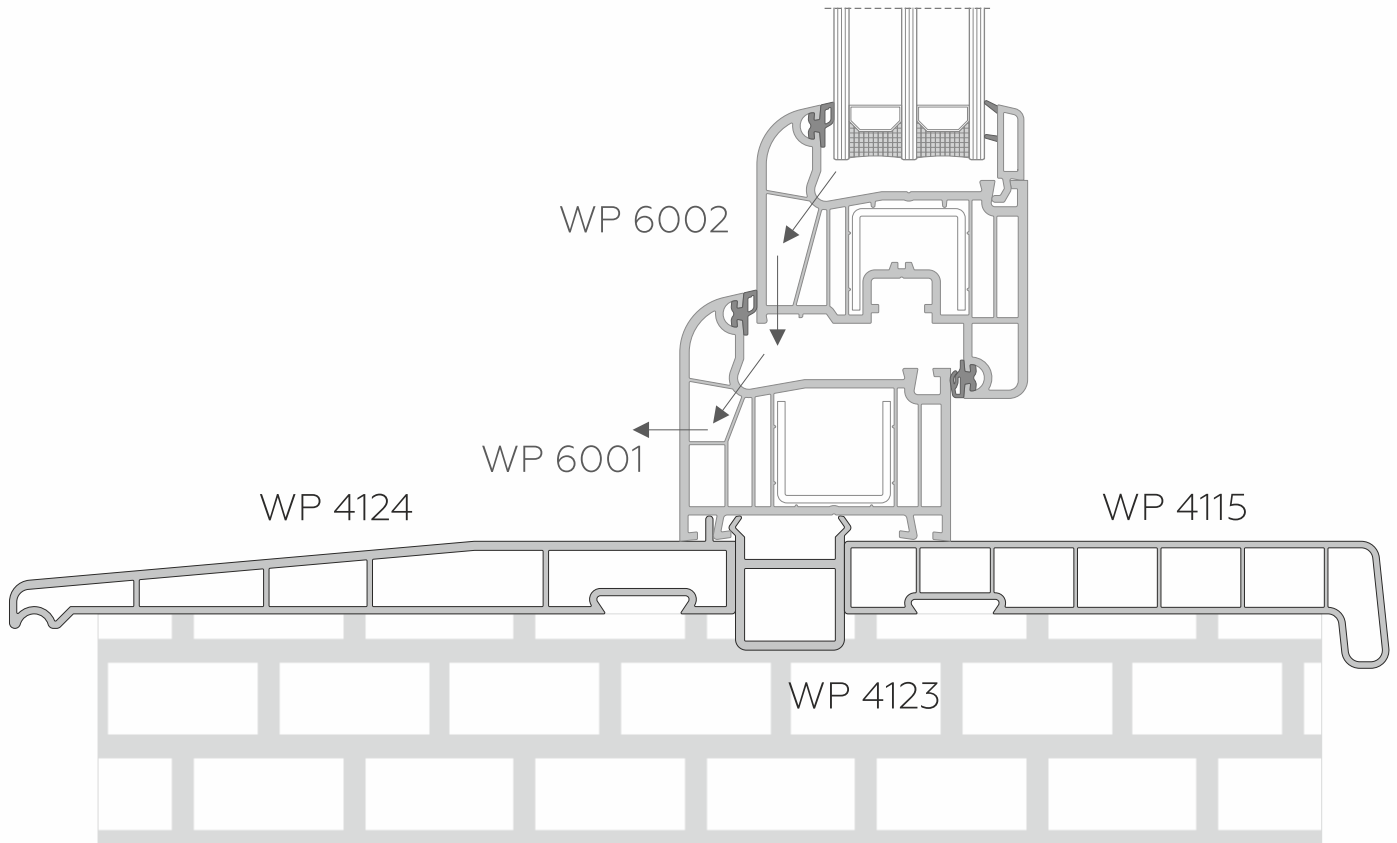

EXPERT WP 6000

Drainage diagram

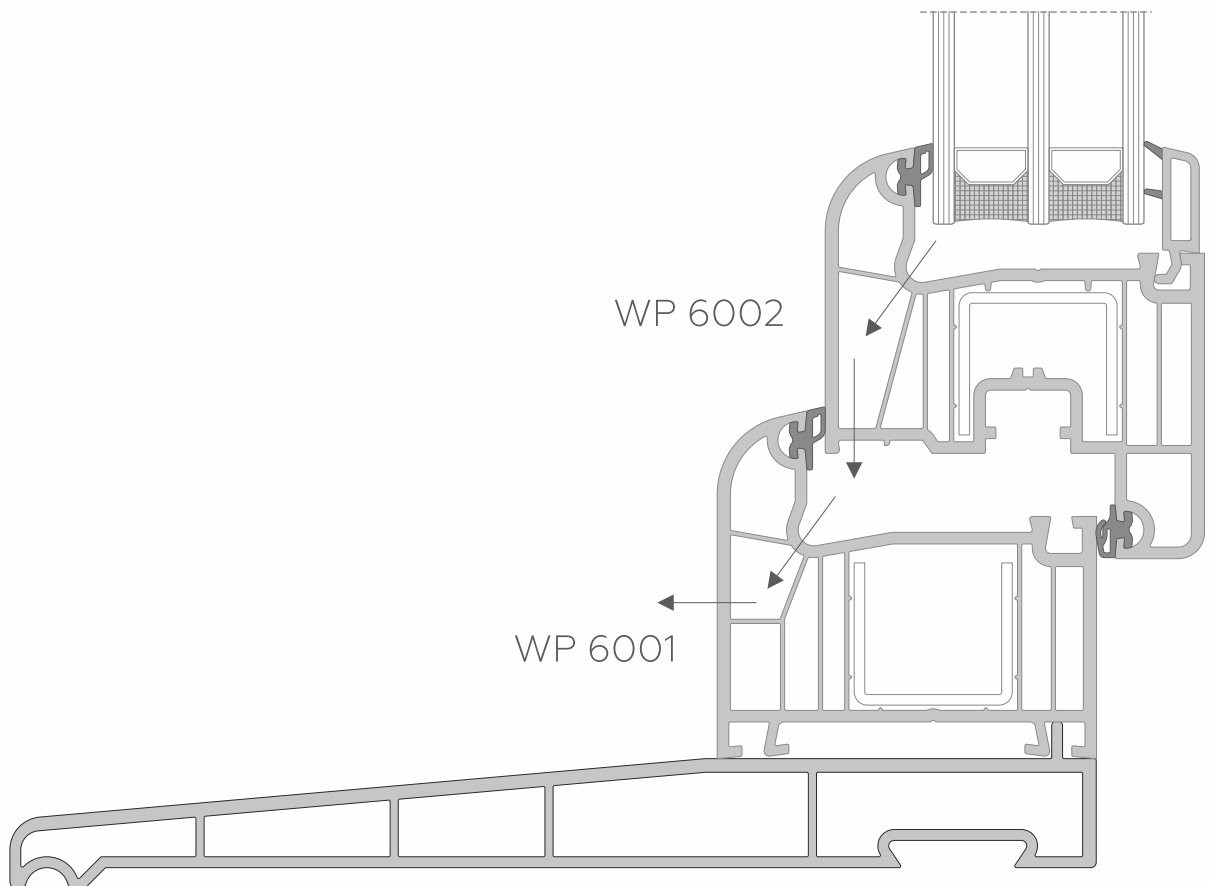
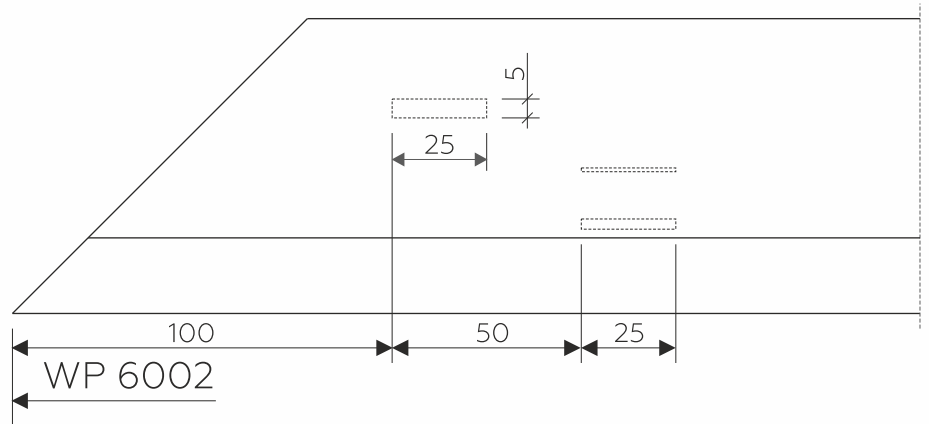
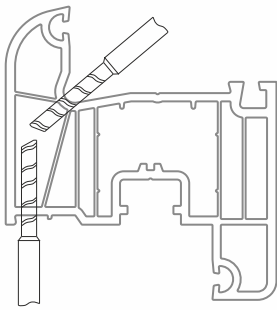
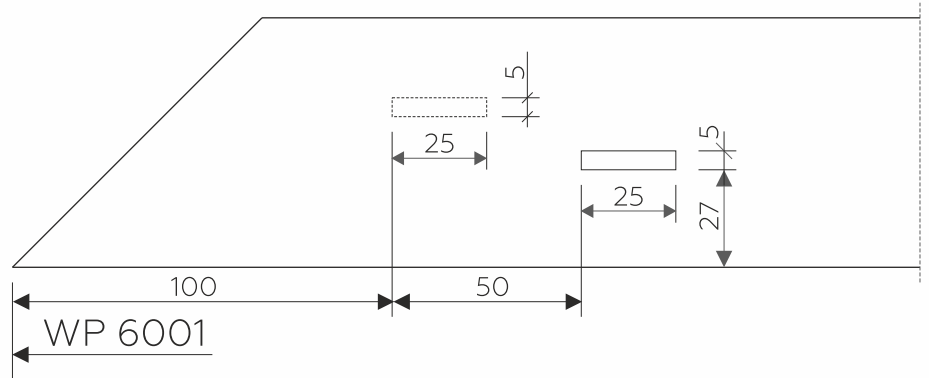
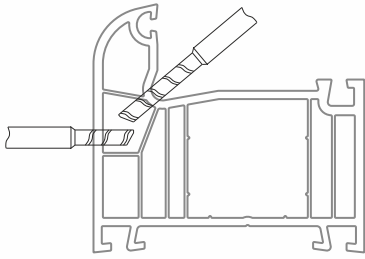
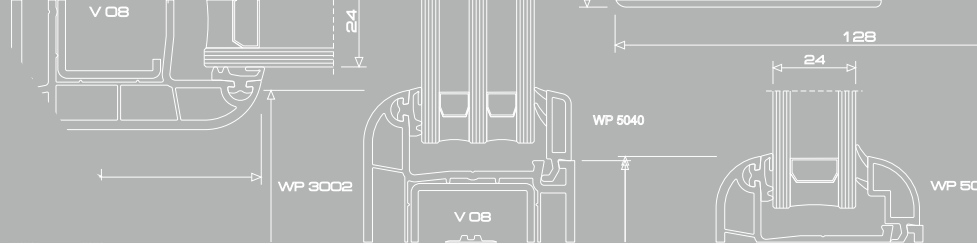

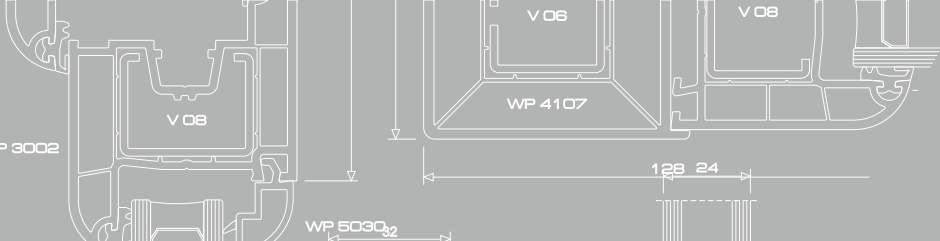

EXPERT WP 6000

Mullion milling

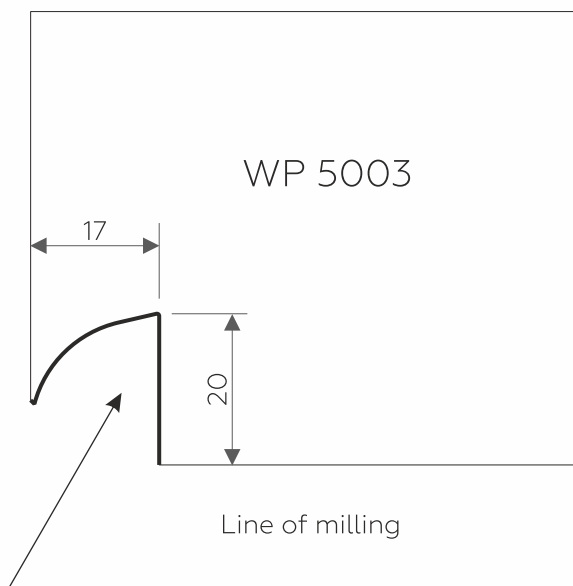

Plastic joint

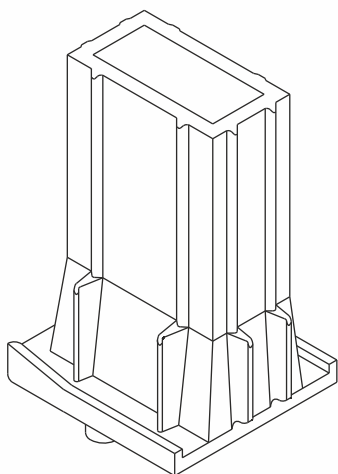

Metal joint

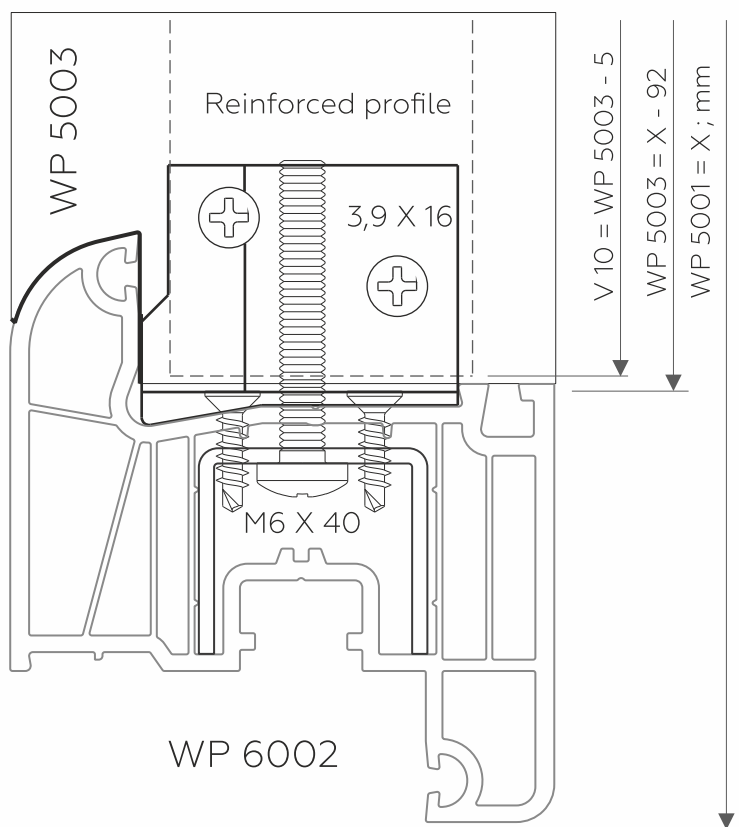
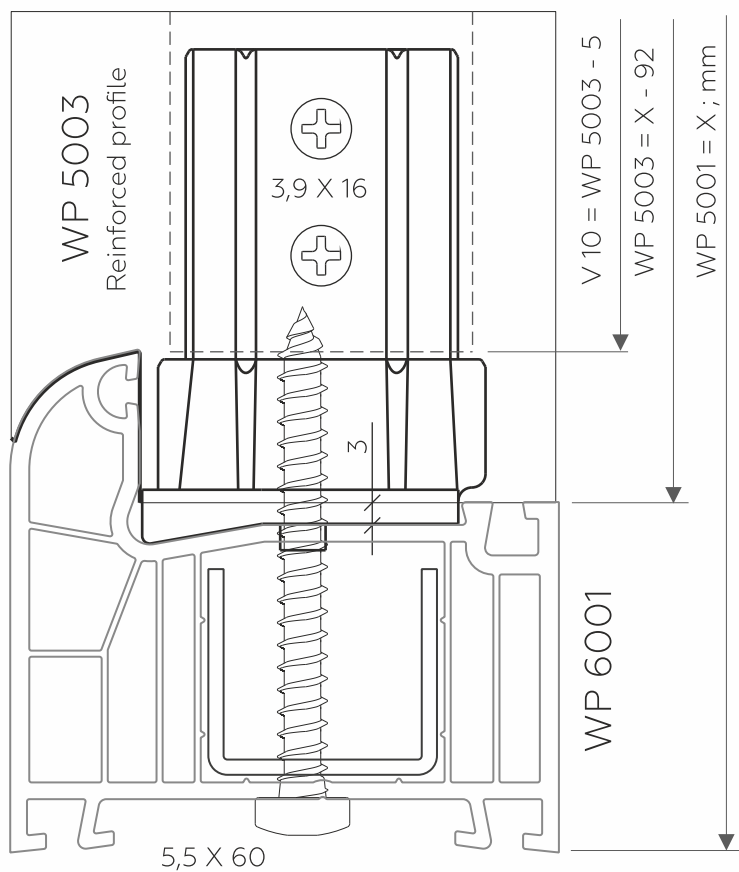
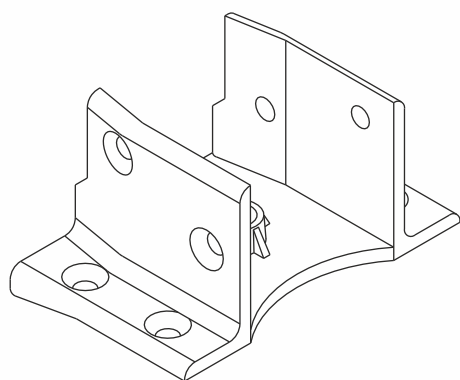

EXPERT WP 6000

Scheme Mullion - Frame

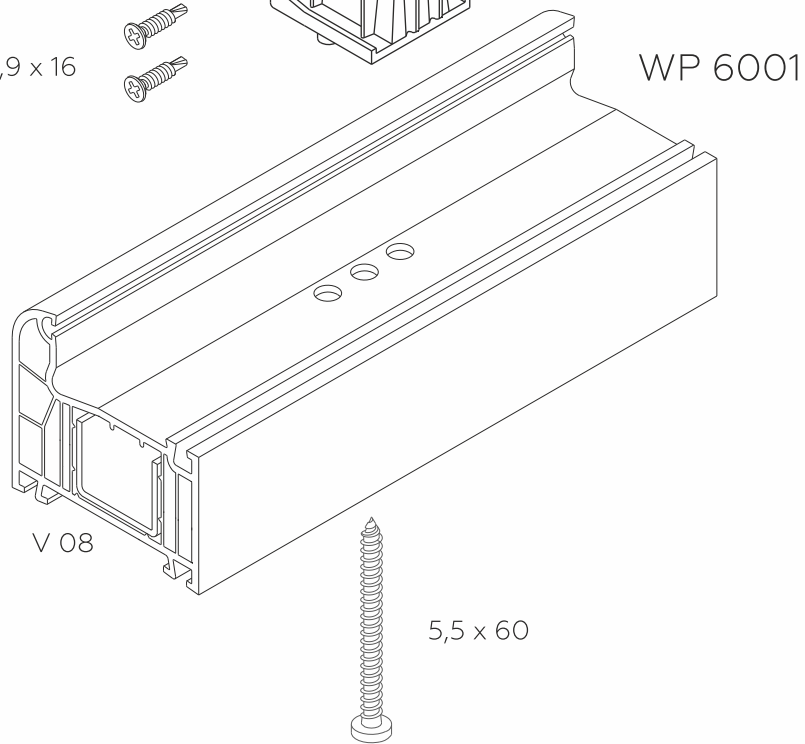
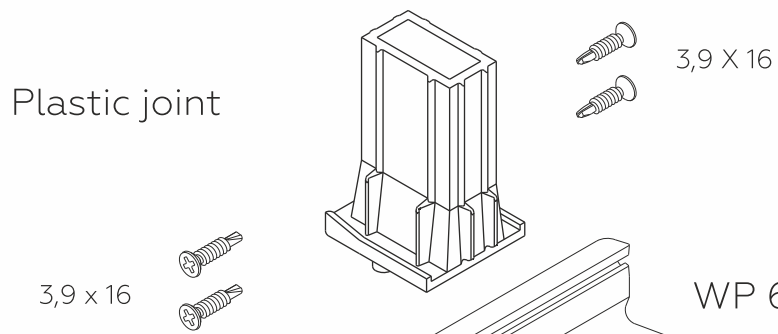
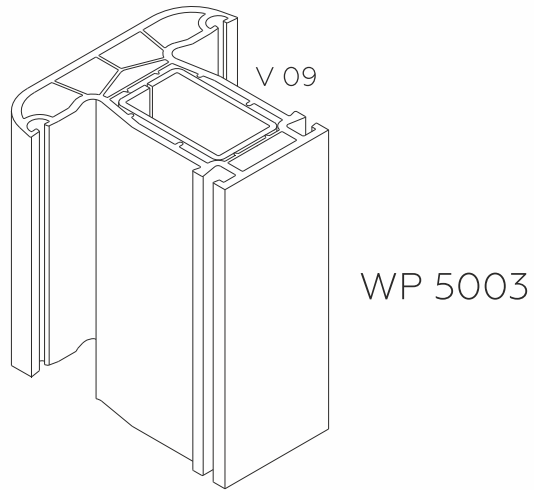
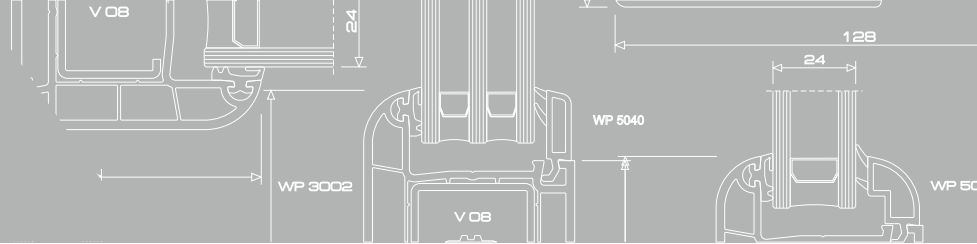

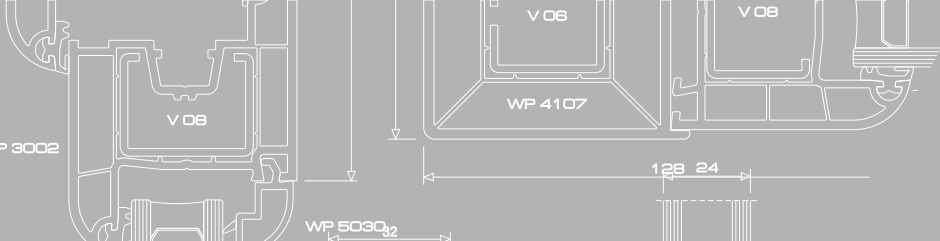

EXPERT WP 6000

Scheme mullion - mullion

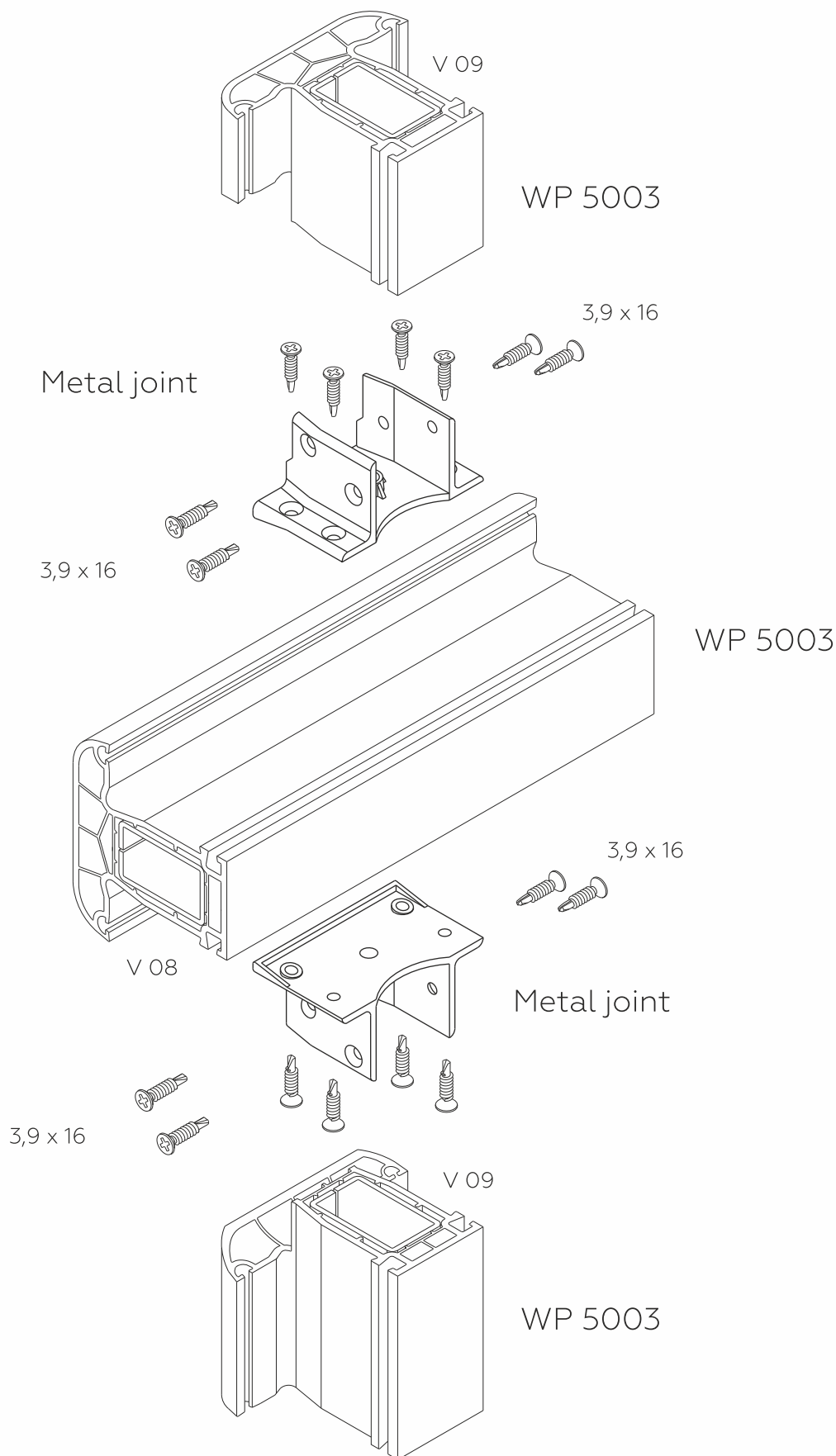

EXPERT WP 6000

Scheme Lap joint profile

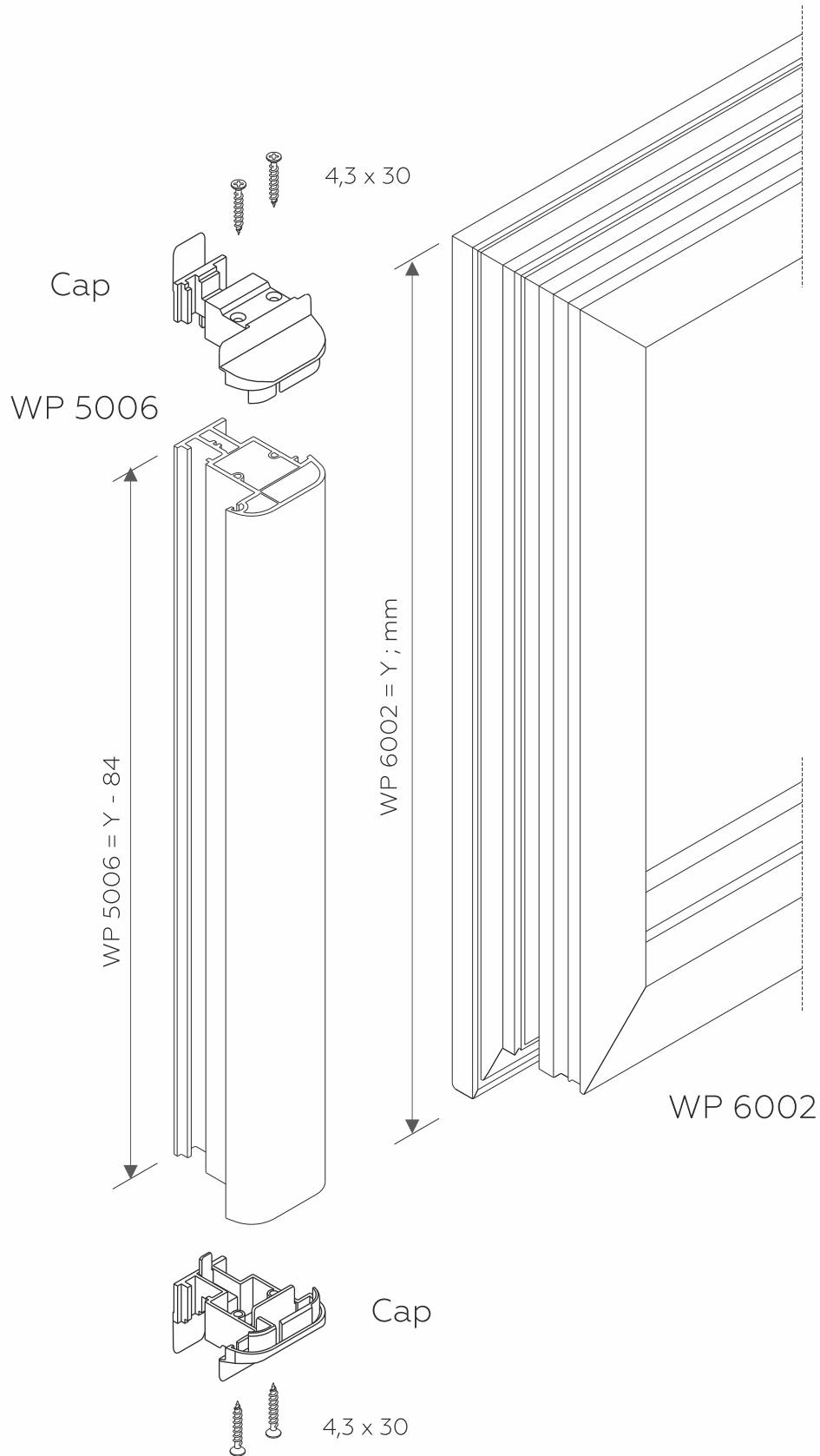
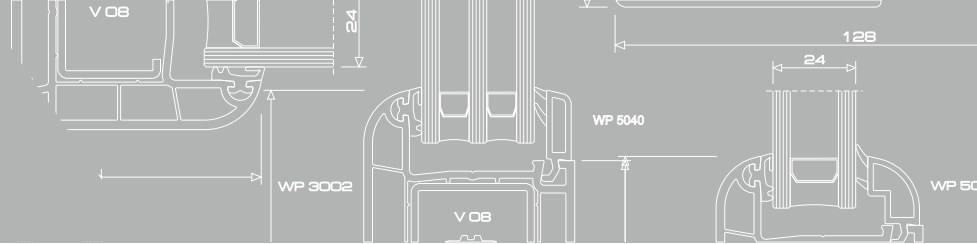

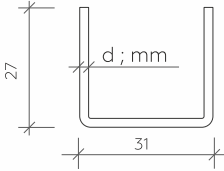
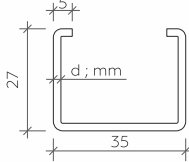
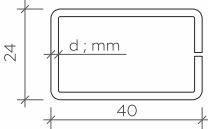
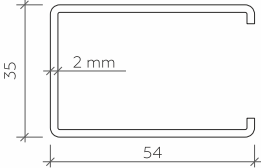
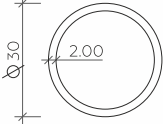
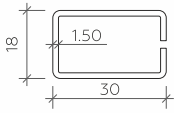
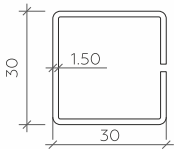
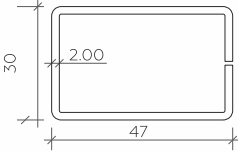
Code	PVC profile	Reinforced profiles	Inertia moment	
V 01	WP 6001 WP 6002		d = 1,5	$I_x = 1,04 \text{ cm}^4$ $I_y = 1,93 \text{ cm}^4$
			d = 2	$I_x = 1,27 \text{ cm}^4$ $I_y = 2,43 \text{ cm}^4$
V 08	WP 5001 WP 5002 WP 5010 WP 5035		d = 1,5	$I_x = 1,22 \text{ cm}^4$ $I_y = 2,80 \text{ cm}^4$
			d = 2	$I_x = 1,71 \text{ cm}^4$ $I_y = 3,76 \text{ cm}^4$
V 09	WP 5003		d = 1,5	$I_x = 1,71 \text{ cm}^4$ $I_y = 3,76 \text{ cm}^4$
			d = 2	$I_x = 2,14 \text{ cm}^4$ $I_y = 4,76 \text{ cm}^4$
V 13	WP 5004 WP 5005		$I_x = 6,47 \text{ cm}^4$ $I_y = 9,29 \text{ cm}^4$	
V 11	WP 5011		$I_x = 1,73 \text{ cm}^4$ $I_y = 1,73 \text{ cm}^4$	
V 02	WP 5006		$I_x = 0,67 \text{ cm}^4$ $I_y = 1,46 \text{ cm}^4$	
V 06	WP 5007		$I_x = 2,19 \text{ cm}^4$ $I_y = 2,25 \text{ cm}^4$	
V 10	WP 5013		$I_x = 4,17 \text{ cm}^4$ $I_y = 8,35 \text{ cm}^4$	

EXPERT WP 6000

Graphics for finding the maximum size of the sashes

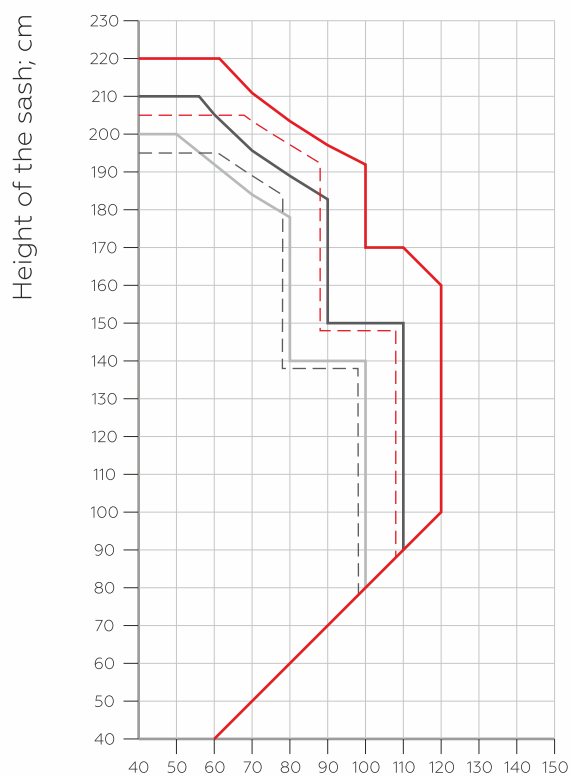
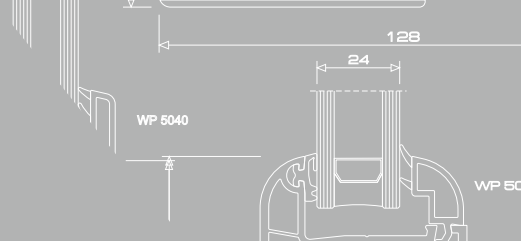

Graphic 2 Width of the sash; cm

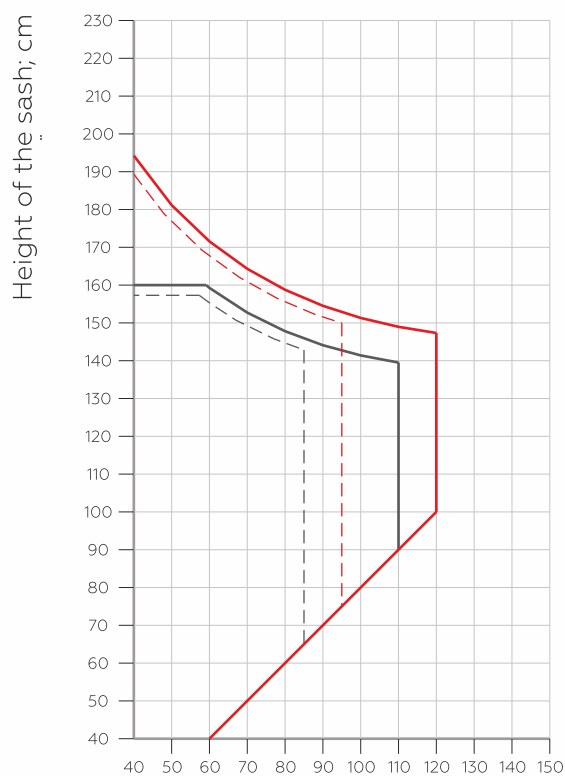

Graphic 1 Width of the sash; cm

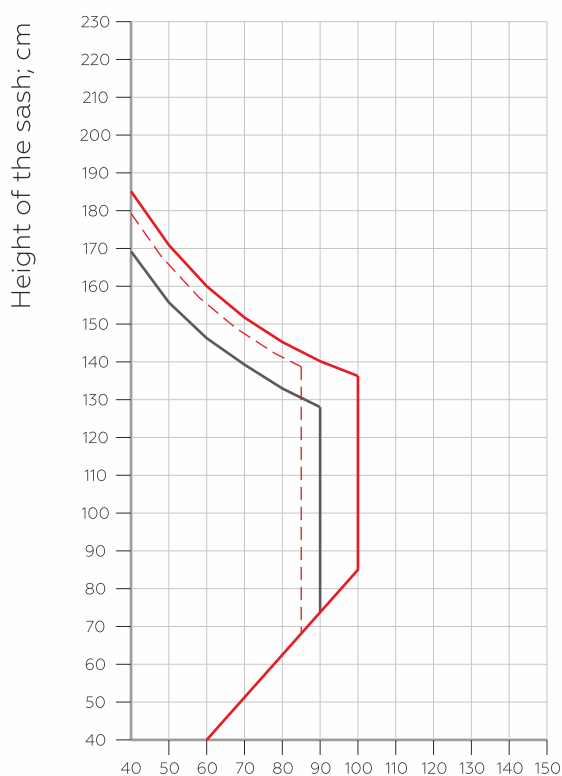

Graphic 3 Width of the sash; cm

- V08 / 2,0 mm / $I_x = 1,51 \text{ cm}^4$; $I_y = 3,53 \text{ cm}^4$
- V08 / 1,5 mm / $I_x = 1,24 \text{ cm}^4$; $I_y = 2,80 \text{ cm}^4$
- V08 / 1,2 mm / $I_x = 1,02 \text{ cm}^4$; $I_y = 2,32 \text{ cm}^4$

The graphics for choosing reinforcement profiles for laminated profiles are with dotted line.

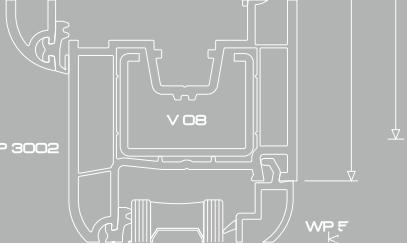

EXPERT WP 6000

Calculation of the moment of inertia

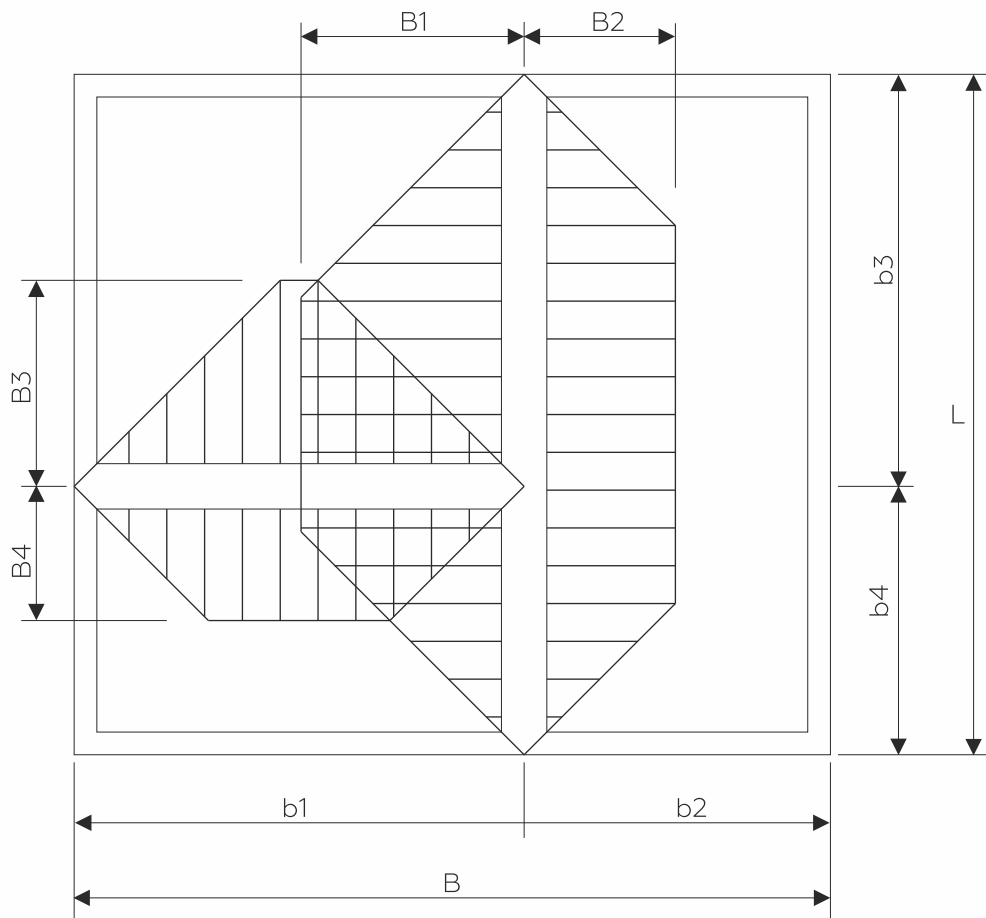

Calculating the moment of inertia

$$I_H = \frac{W \cdot L^4 \cdot B/2}{1920 \cdot E \cdot f} \left[25 - 40 \left(\frac{B}{L} \right)^2 + 16 \left(\frac{B}{L} \right)^4 \right]; \text{ cm}^4$$

W- Wind pressure N/mm²

Height of the building 0-8m: **W** = 600 Pa

W=0,0006 N/mm²

Height of the building 8-20m: **W** = 960 Pa

W=0,0096 N/mm²

Height of the building 20-100m: **W** = 1320 Pa

W=0,00132 N/mm²

Height of the building 20-100m: **W** = 1320 Pa

W=0,00132 N/mm²

L - Height; cm

B - Width; cm

E - Elasticity module

E_{steel} = 210 000 N/mm²

E_{aluminium} = 70 000 N/mm²

f- Slack eligibility (f=L/300; f<0,8 cm)

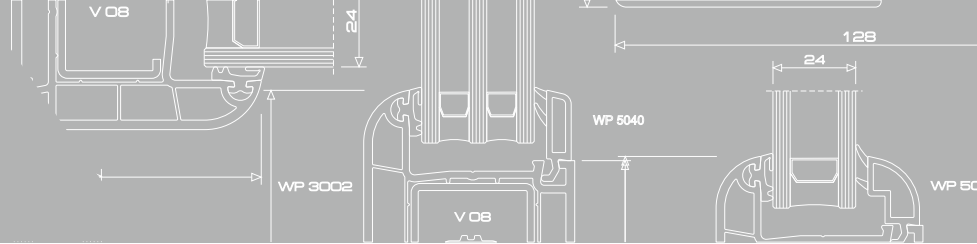

Double opening window with mullion

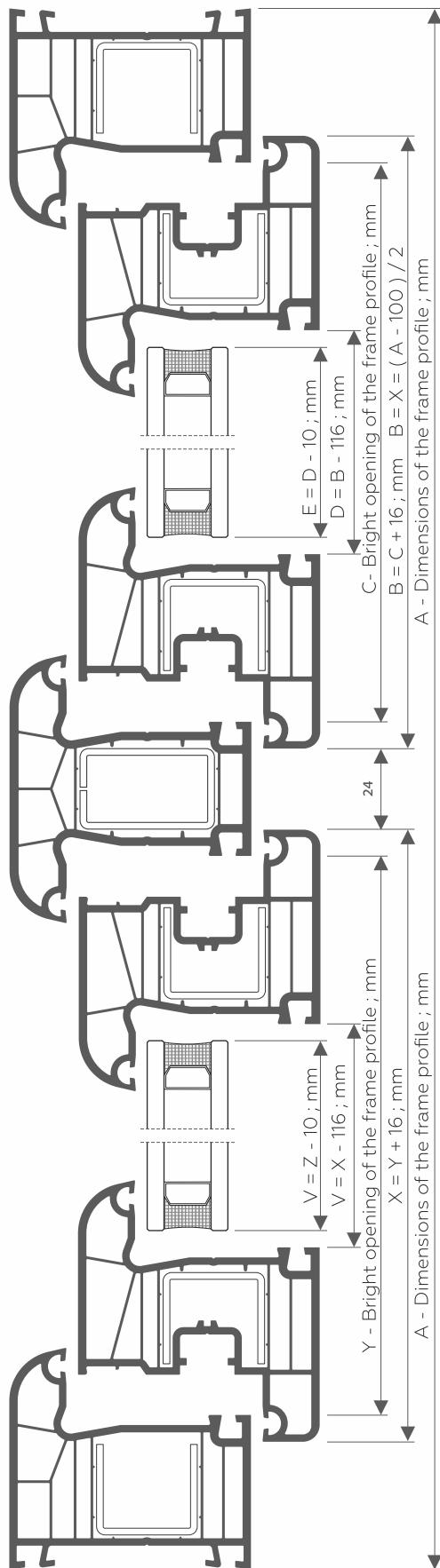

A single opening window

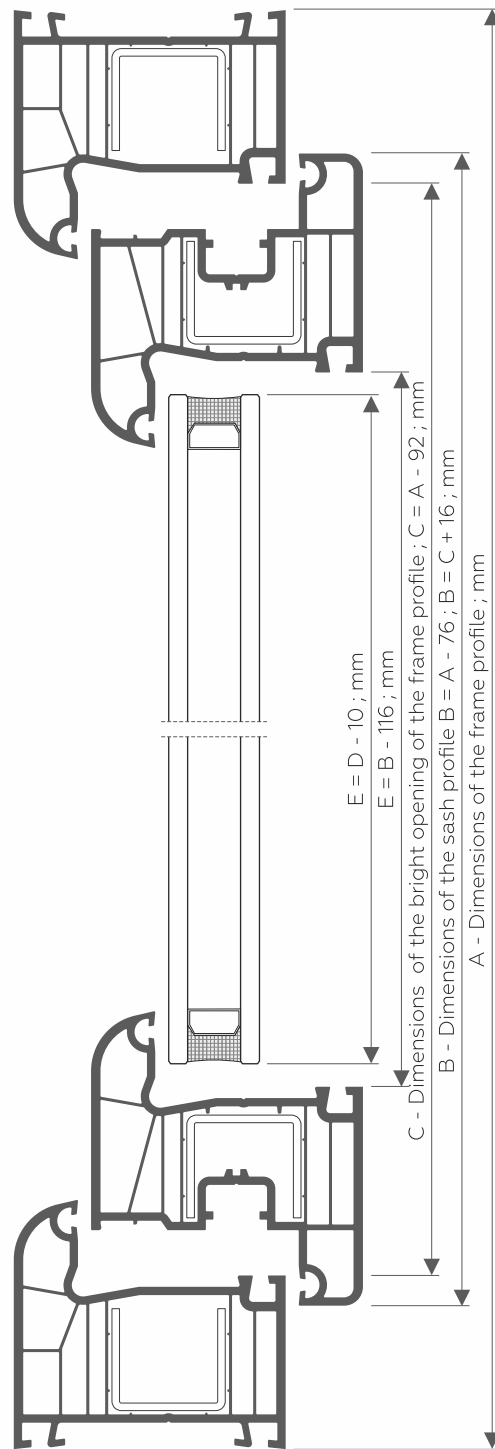

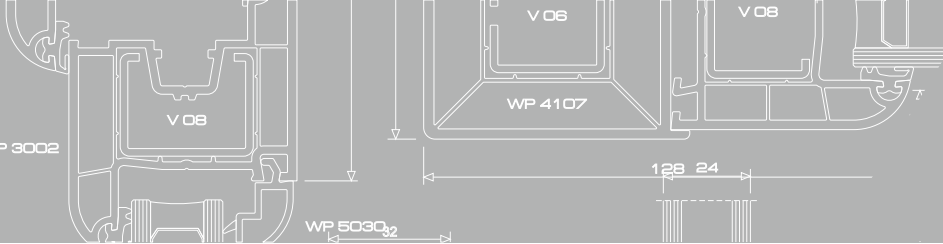

Double opening window with a lap joint profile

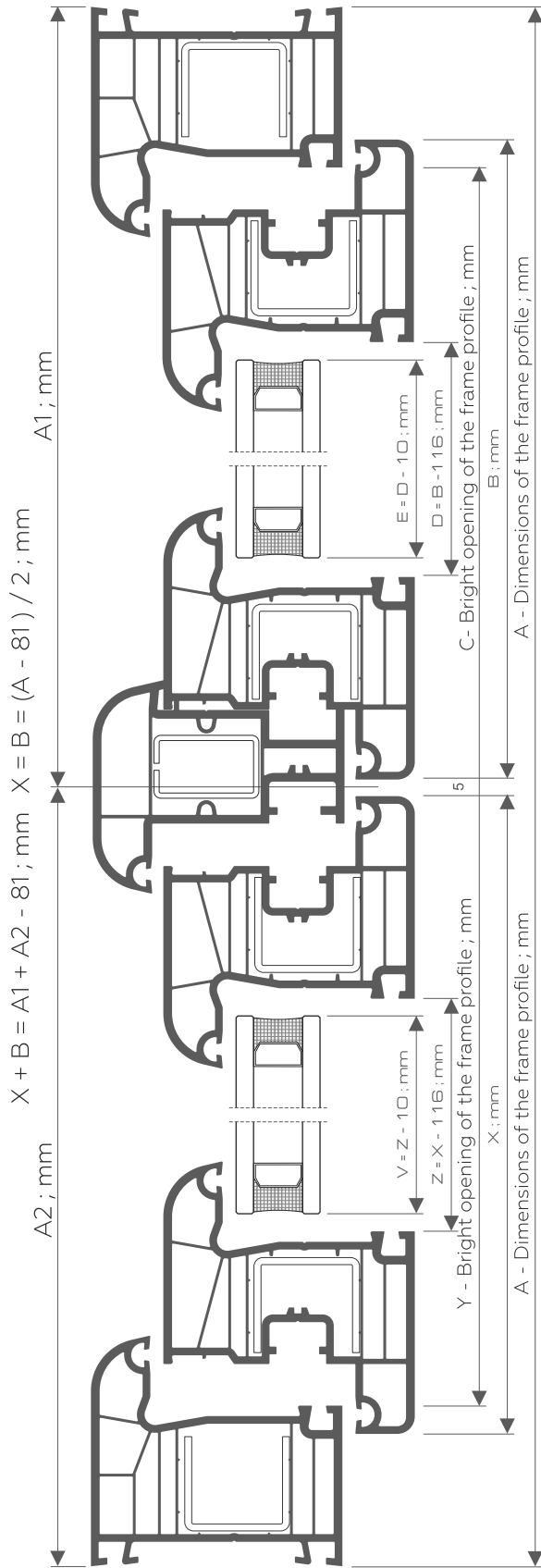

Door with aluminium door sill

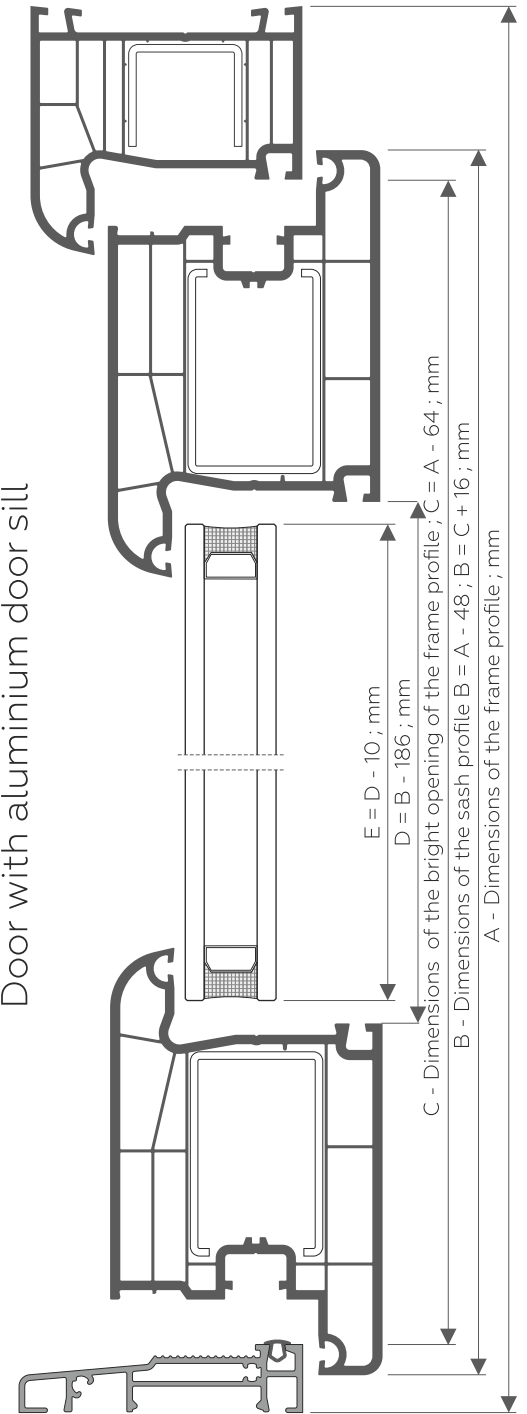

EXPERT WP 6000

Profiles with laminate and arcs

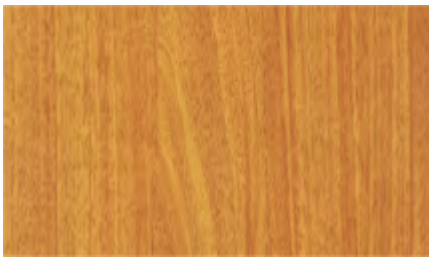
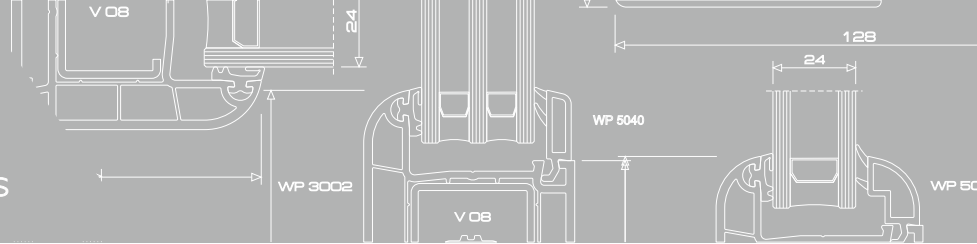

Light walnut

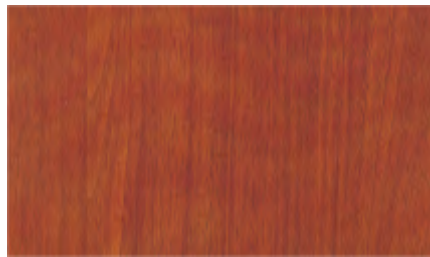

Dark walnut



Cherry



Golden oak



Dark oak

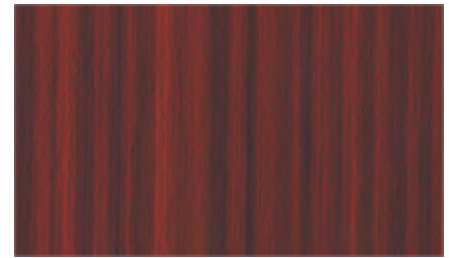

Mahogany



Arcs:

Minimum radius of the arc: 350mm.

Maximum radius: 2860mm.

Maximum length of the chord: 2000 mm.

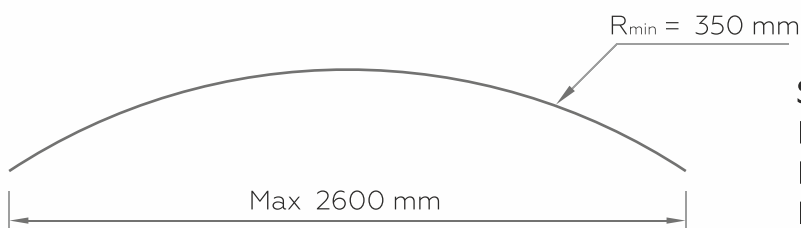



Semicircles:

Minimum radius of the semicircle: 350mm.

Maximum radius: 880mm.

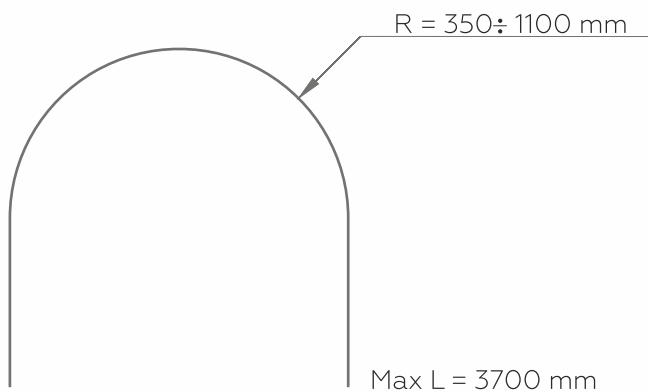
Maximum length of the curve together with the two verticals: 3700 mm.





Head office: 8 Iliensko Shouse str., 1220 Sofia, Bulgaria, Tel: + 359 2/9360093, Fax + 359 2/9360897

www.weissprofil.bg

office@weissprofil.bg